

**SURE SHORT QUESTIONS – MINIMUM LEVEL UPTO 50%**

**CLASS : XII**

**SUBJECT : COMPUTER SCIENCE**

**Q 1 (a) 2 Marks Theory Questions**

1. Explain the use of inline function in C++ with the help of an example.
2. Differentiate between a run time error and syntax error. Also give suitable examples of each in C++.
3. Explain the concept of type-casting in C++ using an example.
4. What is the significance of access specifiers in a class ?
5. What is 'this' pointer? What is its significance?
6. What is the difference between a Local and a Global Variable?

**Q 1 (a) 1 Mark Header Files Questions**

1. Name the header file(s) that shall be needed for successful compilation of the following C++ code.

```
void main ( )
{
    char string [20];
    gets (string);
    strcat(String, CBSE);
    puts (string);
}
```

2. Name the header file(s) that shall be needed for successful compilation of the following C++ code.

```
void main ( )
{
    int Last=25;
    for(int C=9;C<=Last;C++)
    {
        cout<<C<<" : " <<sqrt(C)<<endl;
    }
}
```

3. Name the header files that shall be required for successful compilation of the following C++ program :

```
int main( )
{
    char str[20];
    cout<<fabs(-34.776);
    cout<<"\n Enter a string : ";
    cin.getline(str,20);
    return 0;
}
```

4. Observe the following C++ code and write the name(s) of the header file(s), which will be essentially required to run it in a C++ compiler:

```
void main()
{
    char ch, str[20];
    cin>>str;
    ch=tolower(str[0]);
    cout<<str<<"Starts with"<<ch<<endl;
}
```

5. Name the header files that shall be needed for the following code:

```
void main( )
{
    char Text[ ] = "Welcome to C++ Prog.";
    cout<<setw(20)<<Text;
}
```

Q 1 (c) 2 Marks Error finding Questions

1. Rewrite the following program after removing all the syntax error(s), if any. Underline each correction.

```
#include<iostream.h>
struct Pix
{
    int Color, Style ;
}
void ShowPoint(Pix P)
{
    cout<<P.Color,P.Style<<endl;
}
void main()
{
    Pix Point1 = (5,3);
    ShowPoint(Point 1);
    Pix Point2 = Point1
    Color.Point1+=2;
    ShowPoint(Point2);
}
```

}

2. Re-write the following code segment removing the errors, underlining each correction:

```
#include<iostream.h>
class Student{
int num =0;
char name[ ];
public:
    void getdata()
    {
        cin>>num;
        cin.getline(name);
    }
};
void main()
{
    Student obj;
    getdata();
}
```

3. Rewrite the following program after removing the syntactical error(s), if any. Underline each correction.

```
#include<iostream.h>
const int multiple 3;
void main( )
{
    value=15;
    for(int c=0,c<=5,c++;value-=2)
        if(value%multiple= 0)
            cout<<value*multiple;
            cout<<endl;
        else
            cout>>value+multiple<<endl;
}
```

Q 1 (d) & (e) 2 Marks Output Finding Questions

1. Find the output of the following program.

```
#include <iostream.h>
#include <string.h>
#include<ctype.h>
void main()
{
    int chcount = 0,i=0, len;
    char ch[80] = "Programming Language C++";
```

```

len = strlen(ch);
while(i <= (len-1))
{
    chcount++;
    if(islower(ch[i]))
        ch[i]=toupper(ch[i]);
    else if (isupper(ch[i]))
        ch[i] = toupper(ch[i]);
    cout<<ch[i];
    ++i;
}
cout<<chcount;
}

```

2. Find the output of the following program:

```

#include<iostream.h>
#include<ctype.h>
struct colors
{
    int x, y, z;
};
void shuffle(colors &col, int pos=1)
{
    col.x+=pos; col.y-=pos; col.z*=pos;
}
int main()
{
    colors me={10,20, 5};
    shuffle(me, 2);
    shuffle(me);
    cout<<me.x<<':'<<me.y<<':'<<me.z;
}

```

3. Give the output of the following program :

```

#include<iostream.h>
int global=10;
void func(int &x, int y)
{
    x=x-y;
    y=x*10;
    cout<<x<<","<<y<<"\n";
}
void main()
{
    int global=7;
    func(::global,global);
}

```

```

    cout<<global<<","<<::global<<"\n";
    func(global,::global);
    cout<<global<<","<<::global<<"\n";
}

```

4. Give the output of the following program:

```

#include<iostream.h>
struct pixel
{
    int c,r;
};
void display(pixel p)
{
    cout<<p.c<<" "<<p.r<<endl;
}
void main()
{
    pixel x={40,50},y,z;
    z=x;
    x.c+=10;
    y=z;
    y.c+=10;
    y.r+=20;
    z.c-=15;
    display(x);
    display(y);
    display(z);
}

```

5. write the output of the following programme segment:

```

char *name="ComPUteR";
for (int x=0;x<strlen(name);x++)
if(islower(name[x]))
    name[x]=toupper(name[x]);
else
    if(isupper(name[x]))
        if(x%2==0)
            name[x]=tolower(name[x]);
        else
            name[x]=name[x-1];
puts(name);

```

Q 1 (f)2 Marks Random Number Questions

1. In the following program, find the correct possible output(s) from the options:

```

#include<stdlib.h>
#include<iostream.h>
void main()
{
    randomize();
    char City[ ][10]={"DEL","CHN","KOL","BOM","BNG"};
    int Fly;
    for(int I=0;I<3;I++)
    {
        Fly=random(2)+1;
        Cout<<City[Fly]<<" ";
    }
}

```

Outputs:

- |       |              |      |              |
|-------|--------------|------|--------------|
| (i)   | DEL:CHN:KOL: | (ii) | CHN:KOL:CHN: |
| (iii) | KOL:BON:BNG: | (iv) | KOL:CHN:KOL  |

2. Predict the output of the following program and give justification

```

#include<iostream.h>
#include<stdlib.h>
void main()
{
    int low = 10, p=5;
    randomize();
    for(int i=1;i<=4;++i)
    {
        cout<<(random(p)+low);
        cout<<" ";
        p--;
    }
}

```

i) 13:13:14:10: ii) 14:14:11:11 iii) 14:13:11:11: iv) 14:13:13:11:

3. In the following program if the value of N given by the user is 20, what maximum and minimum value the program could possibly display?

```

#include<iostream.h>
#include<stdlib.h>
void main()
{
    int N,Guessme;
    randomize();
    cin>>N;
    Guessme=random(N-10) + 10;
    cout<<Guessme<<endl;
}

```

4. Observe the following program SCORE.cpp carefully,if the value of num entered by the user is 5,choose the correct possible output(s) from the following options.

```

#include<stdlib.h>
#include<iostream.h>
void main()
{
    randomize();
    int num,Rndnum;
    cin>>num;
    Rndnum=random(num) + 5;
    for(int n=1;n<==Rndnum;n++)
    cout<<n<<" ";
}

```

Output Options:

- (i) 1 2 3 4      (ii) 1 2      (iii) 1 2 3 4 5 6 7 8 9      (iv) 1 2 3

### Q2 (a) 2 Marks Theory Questions

1. What is "this" pointer ? Give an example to illustrate the use of it in C++.
2. Differentiate between constructor and destructor function in context of classes and objects using C++
3. What is Polymorphism in object oriented programming? Explain with example. Name a mechanism in C++ that uses this concept.

### Q2 (b) 2 Marks Constructor & Destructor Questions

1. Answer the questions (i) and (ii) after going through the following program :

```

class AirIndia
{
    char flightno[5];
    int noofpassenger;
public :
    AirIndia ( ) // Function 1
    {
        strcpy( flightno,"");
        noofpassenger=0;
    }
    AirIndia (char str[ ], int n) // Function 2
    {
        strcpy (flightno,str);
        noofpassenger=n;
    }
    void input( ) // Function 3
    {
        cin>>flightno;
        cin>>noofpassenger;
    }
    ~ AirIndia ( ) // Function 4
    {
        cout<<"counter closed"<<endl;
    }
};

```

- (i) In Object Oriented Programming, which concept is illustrated by Function 1 and Function 2 together? Write the statement to call these functions.  
 (ii) In Object Oriented Programming, what is Function 4 referred as and when does it get invoked/called?

```
2. class testmeout
{
    int rollno;
    public:
        ~testmeout() //Function 1
        {
            cout<<rollno<<" is Leaving examination hall"<<endl;
        }
        testmeout() //Function 2
        {
            rollno=1;
            cout<<rollno<<" is appearing for examination "<<endl;
        }
        testmeout(int n, char name[]) //Function 3
        {
            rollno=n;
            cout<<name<<" is in examination hall"<<endl;
        }
        testmeout(testmeout & t);//function 4
        void mywork() //Function 5
        {
            cout<<rollno<<" is attempting questions "<<endl;
        }
};
```

- i) In object oriented programming, what is Function 1 referred as and when does it get invoked?  
 ii) In object oriented programming, what is Function 2 referred as and when does it get invoked?  
 iii) In object oriented programming, what is Function 3 referred as and when does it get invoked?  
 iv) Write a statement so that function 3 gets executed? Complete the definition of function 4  
 v) What will be the output of the above code if its main function definition is as given below (assumed the definition of Function 4 is completed) :

```
main()
{
    testmeout ob1;
    ob1.mywork();
}
```

- vi) Which feature of object oriented programming is demonstrated using Function 2, Function 3 and Function 4 in the above class testmeout?

3. Answer the questions (i) and (ii) after going through the following class :

```
Class maths
{
    char chapter [20];
```

```

int Marks [20]
public:
    Maths ( )
    {
        strcpy (chapter, ``geometry``); //member Function 1
        Marks =10;
        cout <<``chapter Intialised ``;
    }
    ~Maths ( ) //member Function 2
    {
        cout<<`` chapter over ``
    }
};

```

(i) Name the specific features of class shown by member function1 and member function 2 in above example?

(ii) How would Member Function 1 and Member Function 2 get executed?

4. Answer the questions after going through the following code:

```

class Master
{
    char name[10];
public:
    Master()
    {
        cout<<``Object created``;
    }
    Master(Master &o){.....} ;//constructor 2
};

```

- i) What will be the output of the statement Master obj;
- ii) Write complete definition of Constructor 2

### Q2 (c) 4 Marks Class Define Questions

1. Define a class in C++ with the following description :

A data member TrainNumber of type integer.

A data member Destination of type string

A data member Distance of type float

A data member Fuel of type float

A member function CALFUEL( ) to calculate the value of Fuel as per the following criteria :

Distance	Fuel
<=1500	250
more than 1500 and <=3000	1000
more than 3000	2500

Public Members

A function FEEDINFO( ) to allow user to enter values for the Train Number, Destination, Distance & call function CALFUEL() to calculate the quantity of Fuel.  
A function SHOWINFO( ) to allow user to view the content of all the data members.

2. Define a class named Tour in C++ with following description?

Private members:

tcode	integer (Ranges 6 - 10)
adults, children, distance	integer
totalfare	float
AssignFare( )	A function which calculates and assign the value to data member totalfare as follows:-

- For adults	Fare	Distance
	Rs. 500	>=1500

And fare get reduced by 25% if distance is < 1500.

- For Children

For every child a fixed Rs. 50 is charged as fare.

Public members:

- A constructor which initialized initialize all data members with 0
- Function EnterTour() to input the values of the data members tcode, adults, children and call to AssignFare function.
- Function ShowTour() to print all the details of object of Travel type.

3. Define the class BOOK with the following specifications

Private members:

Bookno integer

Title 20 character

Price float

Total\_cost( ) – A function to calculate total cost of N no of copies which is passed to the function as the argument

Public Members:

input( ) – Function to read value of data member of class.

purchase( )-Function to ask the user to input the no of copies to be purchased. It invokes total\_cost() and print the total cost to be paid by the user

4. Define a class “Teacher” with the following specifications:

Private members

Name 20 characters

Subject 10 characters

Basic, DA,HRA float

Salary float

Calculate ( ) function computes the salary and returns it. Salary is the sum of Basic, DA and HRA

Public members

Readdata( ) accepts the data values and invoke the Calculate ( ) function

Displaydata()            function prints the data on the screen

5. Define a class “Item” with following specifications private members of the class “Item” are:

Item\_no                    integer type  
Item\_name                 20 characters  
Price                       float (Price of an item)  
Total\_cost()              A function to calculate the cost of N number of items where N is passed to the function as argument.

Public members of class “Item” are

Input()                    function to read Item\_no, Item\_name, Price  
Purchase ( )              function to ask user to input the no. of items to be purchased it invoked Total\_cost() and print the total cost.

Q2 (d) 4 Marks Inheritance Questions

1. Answer the questions (i) to (iv) based on the following:

```
class CUSTOMER
{
    int cust_no;
    char cust_name[20];
protected:
    void Register( );
public:
    CUSTOMER( );
    void status( );
};
class SALESMAN
{
    int salesman_no;
    char salesman_name[20];
protected:
    float salary;
public:
    SALESMAN( );
    void enter( );
    void show( );
};
class SHOP: private CUSTOMER, public SALESMAN
{
    char voucher_no[10];
    char sales_date[8];
public:
    SHOP( );
    void sales_entry( );
    void sales_detail( );
};
```

- (i) Write the names of data members which are accessible from objects belonging to class CUSTOMER.
- (ii) Write the names of all the member functions which are accessible from objects belonging to class SALESMAN.
- (iii) Write the names of all the members which are accessible from member functions of class SHOP.
- (iv) How many bytes will be required by an object belonging to class SHOP?

2. Answer the questions(i) to (iv) based on the following code :

```
Class trainer
{
    char TNo [20],specializations [10];
    int days;
    Protected:
        float remuneration ;void assignrem(float);
    Public:
        Trainer( );
        void TEntry( );
        void TDisplay( );
};
class Learner
{
    char Regno[10],LName[20],Program[10];
    protected:
        int Attendance, grade;
    public:
        learner( );
        void LEntry( );
        void LDisplay( );
};
class institute : public Learner, Public Trainer
{
    char ICode[10],IName[20];
    public:
        Intitute ( ) ;
        void IEntry ( ) ;
        void IDisplay( );
};
```

- (i) Which type of inheritance is depicted by the above example?
- (ii) Identify the member function (s) that cannot be called directly from the objects of the class institute from the following

```
TEntry( )
LDisplay( )
IEntry( )
```

(iii) Write the names of all the member(s) accessible from member functions of class Institute.

(iv) If class Institute was derived privately from class Learner and privately from class Trainer, then name the member function(s) that could be accessed through Objects of Class Institute

3. Answer the questions after going through the following code:

```
class MARKET {
    int m_no;
    char m_name[20];
protected:
    void register();
public:
    int rating;
    void status();
};
class SHOP:public MARKET {
    int s_no;
    char s_name[20];
public:
    void Enter();
    void Show();
};
class CUSTOMER : private SHOP {
    int c_no,
    char c_name[8];
public:
    void c_Entry();
    void c_Detail();
};
```

- i) Name the type of inheritance expressed in the above class structure.
- ii) Name the data members accessible by the object of class CUSTOMER.
- iii) What is the size of the object of class CUSTOMER?
- iv) Name the data members accessible by the function of class SHOP.

4. Answer the questions (i) to (iii) based on the following code :

```
class stationery
{
    char type;    char manufacturer[10];
public:
    stationery();
    void read_detail();
    void disp_detail();
};
```

```
class office : public stationery
{
    int no_of_type;      float cost_of_sta;
    public:
        void read_off_details();
        void disp_off_details();
};
class printer : private office
{
    int no_of_users;
    char delivery_date[10];
    public:
        void read_pri_details();
        void disp_pri_details();
};
void main()
```

```
{    Printer Myprinter;    }
```

- (i) Mention the Data member and Member function names which are accessible by Myprinter.
- (ii) What is the size of Myprinter in bytes?
- (iii) Mention the names of functions accessible from the member function read\_pri\_details().

5. class MNC

```
{
    char cname[25];
    protected:
    char hoffice[25];
    public:
        MNC()
        {}
        char country[25];
        void enterdata()
        {}
        void displaydata()
        {}
};
class branch : public MNC
{
    long noe;
    char ctry[25];
    protected:
        void association()
        {}
    public:
        Branch()
```

```

        {}
        void add()
        {}
        void show()
        {}
};
class outlet :public branch
{
    char state[25];
    public:
        outlet()
        {
        }
        void enter()
        {}
        void output()
        {}
};

```

(i) Which class constructor will be called first at the time of declaration of an object of class outlet.

(ii) How many bytes does an object belonging to class outlet require?

(iii) Name the member function(s), which are accessed from the object(s) of class outlet.

(iv) Name the data member(s), which are accessible from the object(s) of class Branch.

### Q3 (a) & (d) 1 D / 2 D Array Questions

1. Given an array named A with following elements

3,-5,1,3,7,0,-15,3,-7,-8

write a C++ function to shift all the negative numbers to left so that the resultant array may look like

-5,-15,-7,-8,3,1,3,7,0,3

2. Write a function in C++ which accepts an integer array and its size as arguments and replaces elements having odd values with thrice its value and elements having even values with twice its value.

Example : If an array of 5 elements initially contains the elements as

3, 4, 5, 16, 9

then the function should rearrange the content of the array as

9, 8, 15, 32, 27

3. Write c++ function swap() that accepts an array and its size as arguments and swaps the first half elements with the second half.

For example the following array

4	6	7	8	10	5
---	---	---	---	----	---

Should become

8	10	5	4	6	7
---	----	---	---	---	---

4. Write a function `sumarr()` that accepts a 2D square matrix and its dimension as arguments and prints the sum of the elements at diagonals .

5. Write a function in C++ which accepts a 2D array of integers and its size as arguments and displays the sum of all positive elements of the middle row and sum of all negative elements of middle column.

[Assuming the 2D Array to be a square matrix with odd dimension i.e., 3 x 3, 5 x 5, etc..]

Example, if the array content is

4 -5 7

8 3 -2

9 -1 6

Output through the function should be :

Middle Row : 11

Middle Column : -6

6. Write a function in C++ which accepts an integer array and its size as arguments / parameters and assign the elements into a two dimensional array of integers in the following format :

If the array is 1, 2,3,4,5,6

If the array is 1,2,3

The resultant 2D array is given below

1 2 3 4 5 6

1 2 3 4 5 0

1 2 3 4 0 0

1 2 3 0 0 0

1 2 0 0 0 0

1 0 0 0 0 0

The resultant 2D array is  
given below

1 2 3

1 2 0

1 0 0

7. Write a function in c++ which accepts a 2D array of integers and its size as arguments and displays the elements which lies on diagonals.

[Assuming the 2D array to be a square matrix with odd dimensions, i.e 3x3, 5x5, 7x7, etc ]

Example if the array content is

5 4 3

6 7 8

1 2 9

Output through the function should be

Diagonal one : 5 7 9

Diagonal two : 3 7 1 .

8. Write a function in C++ which accepts a 2D array of integers and its size as arguments and displays the elements of the middle row and the elements of middle column.

Example if the array content is

3 5 4

7 6 9

2 1 8

Output through the function should be:

Middle row: 769

Middle column: 5 6 1

**Q3 (b) Address Finding Questions**

1. An array ARR[15][35] is stored in the memory along the column with each of its elements occupying 8 bytes. Find out the base address and the address of an element ARR[2][5] , if the location ARR[5][10] is stored at the address 4000.
2. An array Array[20][15] is stored in the memory along the column with each element occupying 8 bytes. Find out the base address and address of the element Array[2][3] if the element Array[4][5] is stored at the address 1000.
3. An array P[30][60] is stored in memory along the row with each element occupying 2 bytes. Find the address of the element P[20][30] if the base address is 1800.
4. Each element of a two dimensional array with 5 rows and 4 columns is stored in one memory location . If A(1,1) is at location 2000 what is the address of A(4,4)? The arrangement is row –major. Use a suitable formula for the calculation.
5. Each element of the array A[-15...20, 20...45] requires 1 byte of storage. If the array is stored in column major order beginning location 1000, determine the location of A[0,40]

**Q3 (e) 2 Marks Evaluation of Postfix Expression Questions**

1. Evaluate post fix expression  
$$\text{Expr} = 3 \ 2 \ 6 \ * \ 4 \ / \ + \ 3 \ -$$
2. Evaluate the following postfix expression E given below, show the contents of the stack during the evaluation.  
30, 25, +, 20, 10, -, 12, +, \*
3. Evaluate the expression 5,6,2,+,\*,12,4,/,- ..... in tabular form showing stack status after every step.

**Q4 (b) 2 Marks File Handling Questions**

1. Write a user defined function in C++ to read the content of a text file “JOKE.TXT”, count and display the number of blank spaces present in it.
2. Write a function in C++ to print the count of the word is as an independent word in a text file DIALOGUE.TXT.

For example, if the content of the file DIALOGUE.TXT is

This is his book. Is this book good?

Then the output of the program should be 2.

**Q 5 (a) 2 Marks DBMS Theory Questions**

1. How many types of users work on database systems?
2. What is foreign Key? What is its purpose?
3. Define the terms Tuple and Attribute.
4. What do you understand by the terms Cardinality and Degree of the table?
5. What are DDL and DML?
6. What is the difference between Where and Having Clause ?
7. What do you understand by constraints ?

8. Differentiate between the terms primary key and alternate key.
9. Illustrate the difference between the three levels of data abstraction.
10. Explain Degree and Cardinality with example.

**Q 5 (b) 6 Marks SQL Questions**

1. Write the SQL query commands based on following table.

**Table : Book**

Book_id	Book_name	Author_name	Publisher	Price	Type	Quantity
C0001	Fast Cook	Lata Kapoor	EPB	355	Cookery	5
F0001	The Tears	William Hopkins	First Publi.	650	Fiction	20
T0001	My First c++	Brain & Brooke	FPB	350	Text	10
T0002	C++ Brain works	A.W. Rossaine	TDH	350	Text	15
F0002	Thunderbolts	Anna Roberts	First Publ.	750	Fiction	50

**Table : issued**

Book_Id	Quantity Issued
T0001	4
C0001	5
F0001	2

Write SQL query for (a) to (f)

- (a) To show book name, Author name and price of books of First Pub. Publisher
- (b) To list the names from books of text type
- (c) To Display the names and price from books in ascending order of their prices.
- (d) To increase the price of all books of EPB publishers by 50.
- (e) To display the Book\_Id, Book\_name and quantity issued for all books which have been issued
- (f) To insert a new row in the table issued having the following data. 'F0003', 1
- (g) Give the output of the following
  - i. Select Count(\*) from Book;
  - ii. Select Max(Price) from book where quantity >=15;
  - iii. Select book\_name, author\_name from book where publisher='First Publ.';
  - iv) Select count(distinct publishers) from books where Price >=400;

2. Write the SQL query commands based on following table.

**Table: Employees**

Empid	Firstname	Lastname	Address	City
010	Ravi	Kumar	Raj nagar	GZB
105	Harry	Waltor	Gandhi nagar	GZB
152	Sam	Tones	33 Elm St.	Paris
215	Sarah	Ackerman	440 U.S. 110	Upton
244	Manila	Sengupta	24Friends street	New Delhi
300	Robert	Samuel	9 Fifth Cross	Washington
335	Ritu	Tondon	Shastri Nagar	GZB
400	Rachel	Lee	121 Harrison St.	New York
441	Peter	Thompson	11 Red Road	Paris

**Table: EmpSalary**

Empid	Salary	Benefits	Designation
010	75000	15000	Manager
105	65000	15000	Manager
152	80000	25000	Director
215	75000	12500	Manager
244	50000	12000	Clerk
300	45000	10000	Clerk
335	40000	10000	Clerk
400	32000	7500	Salesman
441	28000	7500	Salesman

Write the SQL commands for the following :

- (i) To show firstname,lastname,address and city of all employees living in paris
- (ii) To display the content of Employees table in descending order of Firstname.
- (iii) To display the firstname,lastname and total salary of all managers from the tables Employee and empsalary , where total salary is calculated as salary+benefits.
- (iv) To display the maximum salary among managers and clerks from the table Empsalary.
- (v) Give the Output of following SQL commands:

- (i) Select firstname, salary from employees, empsalary where designation = 'Salesman' and Employees.empid=Empsalary.empid;
  - (ii) Select count(distinct designation) from empsalary;
  - (iii) Select designation, sum(salary) from empsalary group by designation having count(\*) >2;
  - (iv) Select sum(benefits) from empsalary where designation ='Clerk';
3. Consider the following tables Consignor, Consignee and Consignment. Write SQL commands for the statements (i) to (iv) and give the outputs for SQL queries (v) to (viii).

**Sender**

SenderID	SenderName	SenderAddress	City
ND01	R Jain	2, ABC Appts	New Delhi
MU02	H Sinha	12, Newtown	Mumbai
MU15	S Jha	27/A, Park Street	Mumbai
ND50	T Prasad	122 - K, SDA	New Delhi

**Recipient**

RecID	SenderID	RecName	RecAddress	RecCity
KO05	ND01	R Bajpayee	5, Central Avenue	Kolkata
ND08	MU02	S Mahajan	116, A Vihar	New Delhi
MU19	ND01	H Singh	2A, Andheri East	Mumbai
MU32	MU15	P K Swamy	35, C S Terminus	Mumbai
ND48	ND50	S Tripathi	13, BI D, Mayur Vihar	New Delhi

- (i) To display the names of all Senders from Mumbai
- (ii) To display the RecID, Sendername, SenderAddress, RecName, RecAddress for every Recipient.
- (iii) To display Recipient details in ascending order of RecName
- (iv) To display number of Recipients from each city
- (v) SELECT DISTINCT SenderCity from Sender;
- (vi) SELECT A.SenderName, B.RecName  
From Sender A, Recipient B  
Where A.SenderID = B.SenderID AND B.RecCity ='Mumbai';
- (vii) SELECT RecName, RecAddress  
From Recipient  
Where RecCity NOT IN ('Mumbai', 'Kolkata');
- (viii) SELECT RecID, RecName  
FROM Recipient  
Where SenderID='MU02' or SenderID='ND50';

4. Consider the following tables SUPPLIER and COMPANY. Write SQL queries for the statements i) to iv) and outputs for the statements v) and vi)

TABLE: SUPPLIER

#SNO	PNAME	CID	QTY	PRICE	DISCOUNT
S1	Bread	C1	150	8	
S2	Cake	C1	250	20	
S3	Coffee	C2	170	45	10
S4	Chocolate	C3	380	10	
S5	Sauce	C4	470	36	
S6	Maggi	C5	340	10	20
S7	Biscuit	C5	560	21	
S8	Jam	C6	220	40	25

TABLE: COMPANY

#CID	CNAME
C1	Britannia
C2	Nestle
C3	Amul
C4	Kissan
C5	Marie
C6	Kissan

- i) Display the PNAME, CID and QTY and PRICE for those suppliers who are earning some discount
- ii) Display the supplier details for those suppliers whose CID is C1, C2 or C3.
- iii) Display the CID and minimum QTY for each CID.
- iv) Display the PNAME and PRICE in the descending order of PRICE.
- v) `SELECT PNAME, QTY, CNAME FROM SUPPLIER, COMPANY WHERE SUPPLIER.CID=COMPANY.CID AND QTY>200;`
- vi) `SELECT COUNT(*) FROM SUPPLIER GROUP BY CID HAVING CID NOT IN(C1,C2,C5);`

5. Study the following tables DOCTOR and SALARY and write SQL commands for the questions (i) to (iv) and give outputs for SQL queries (v) to (iv):

Table : DOCTOR

ID	NAMER	DEPT	SEX	EXPERIENCE
101	John	ENT	M	12
104	Smith	ORTHOPEDIC	M	5
107	Rahul	CARDIOLOGY	M	10
114	Lara	SKIN	F	9
109	Mehul	MEDICINE	F	9
105	Jonson	ORGHOPEIC	M	10
117	Lucy	ENT	F	3
111	Becon	Medicine	F	10
130	Morphy	ORTHOPEDIC	M	15

TABLE :SALARY

ID	BASIC	ALLOWANCE	CONSULTATION
101	12000	1000	300
104	23000	2300	500
107	32000	4000	500
114	12000	5200	100
109	42000	1700	200
105	18900	1690	300
130	21700	2600	300

- (a) Display NAME of all doctors who are in “MEDICINE” having more than 10 years experience from table DOCTOR.
- (b) Display the average salary of all doctors working in “ENT” department using the tables DOCTOR and SALARY. Salary=BASIC+ALLOWANCE.
- (c) Display the minimum ALLOWANCE of female doctors.

- (d) Display the highest consultation fee among all male doctors.
- (e) SELECT count(\*) from DOCTOR where SEX='F';
- (f) SELECT NAME, DEPT, BASIC from DOCTOR, SALARY where DEPT='ENT' and DOCTOR.ID=SALARY.ID

**Q 6 (a) 2 Marks Boolean Algebra Questions**

1. State and verify Duality principle.
2. State and verify Absorption law in boolean algebra.
3. State Distributive law and verify the same using truth table.
4. Minimize the Boolean expression  $X'Y'Z'+X'Y'Z+X'YZ'+X'YZ'+XY'Z'+XY'Z+XYZ'$  algebraically

**Q 6 (b) Logic Circuit Questions**

1. Draw logic circuit diagram for the following expression:  
 $ab + b'c + c'a'$
2. Write the equivalent Boolean Expression for the following Logic circuit.

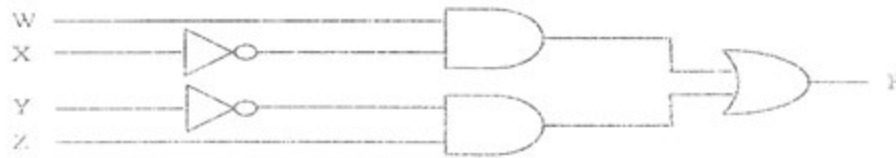

3. Write the Boolean expression for the following Logic gate:

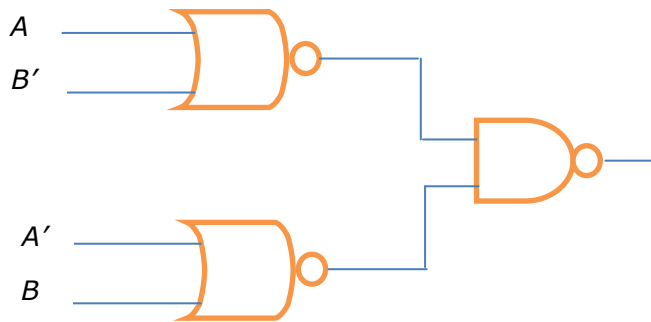

4. Write the equivalent Boolean expression for the following Logic Circuit:

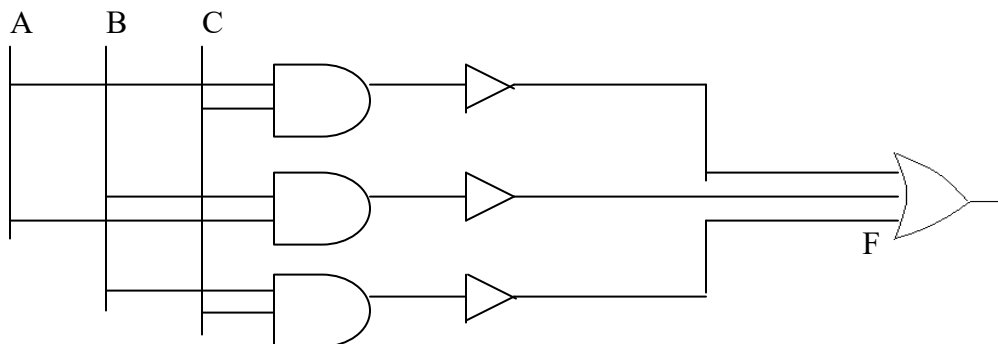

**Q 6 1 Mark SOP /POS Questions**

1. Write the SOP form from the following table:

A	B	C	F
0	0	0	1
0	0	1	0
0	1	0	0
0	1	1	1
1	0	0	0
1	0	1	0
1	1	0	1
1	1	1	1

2. Write the equivalent Canonical Sum of Product expression for the following Product of Sum Expression  
 $F(X, Y, Z) = \prod(1, 3, 6, 7)$
3. Write the canonical POS for the Boolean function G which is represented in the following truth table:

A	B	C	G
0	0	0	0
0	0	1	1
0	1	0	0
0	1	1	1
1	0	0	0
1	0	1	1
1	1	0	0
1	1	1	0



- (viii) HTTP
  - (ix) URL
  - (x) TCP/IP
20. Explain the term FIREWALL.

**Q 7 4 Marks Networking Questions**

1. “China Middleton Fashion” is planning to expand their network in India, starting with two cities in India to provide infrastructure for distribution of their product. The company has planned to setup their main office in Chennai at three different locations and have named their offices as “Production Unit” and “Media Unit”. The company has its corporate unit in Delhi. A rough layout of the same is as follows:      5

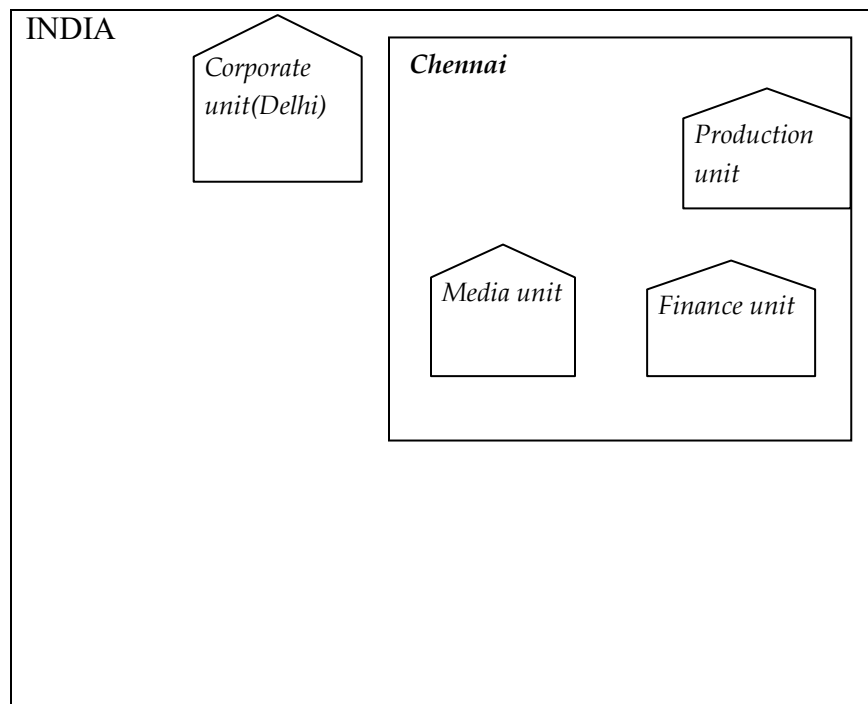

Approximate distance between these Units is as follows:

From	To	Distance
Production Unit	Finance Unit	70 MTR.
Production Unit	Media Unit	15KM
Production Unit	Corporate Unit	2112KM
Finance Unit	Media Unit	15KM

In continuation of the above, the company experts have planned to install the following number of computers in each of their offices:

Production Unit	150
Finance Unit	35
Media Unit	10
Corporate Unit	30

- (i) Suggest the kind of network required(out of LAN, MAN, WAN) for connecting each of the following office units:
  - ✓ Production Unit and Media Unit
  - ✓ Production Unit and Finance Unit
- (ii) Which one of the following devices will you suggest for connecting all the computers within each of their office units?
  - ✓ Switch / Hub
  - ✓ Modem
  - ✓ Telephone
- (iii) Which of the following communication media, you will suggest to be procured by the company for connecting their local office units in Chennai for very effective(High Speed) Communication?
  - ✓ Telephone Cable
  - ✓ Optical Fibre
  - ✓ Ethernet Cable
- (iv) Suggest a cable/wiring layout for connecting the company's local office units located in Chennai. Also, Suggest an effective method/technology for connecting the company's office unit located in Delhi.

- 
2. "Bhartiya Connectivity Association" is planning to spread their offices in four major cities in India to provide regional IT infrastructure support in the field of Education & Culture . The company has planned to setup their head office in New Delhi in three locations and have named their New Delhi offices as "Front office" ,"Back Office" and "Work Office". The company has three more regional offices as "South Office" , "East Office" and " West Office" located in other three major cities of India. A rough layout of the same as follows :

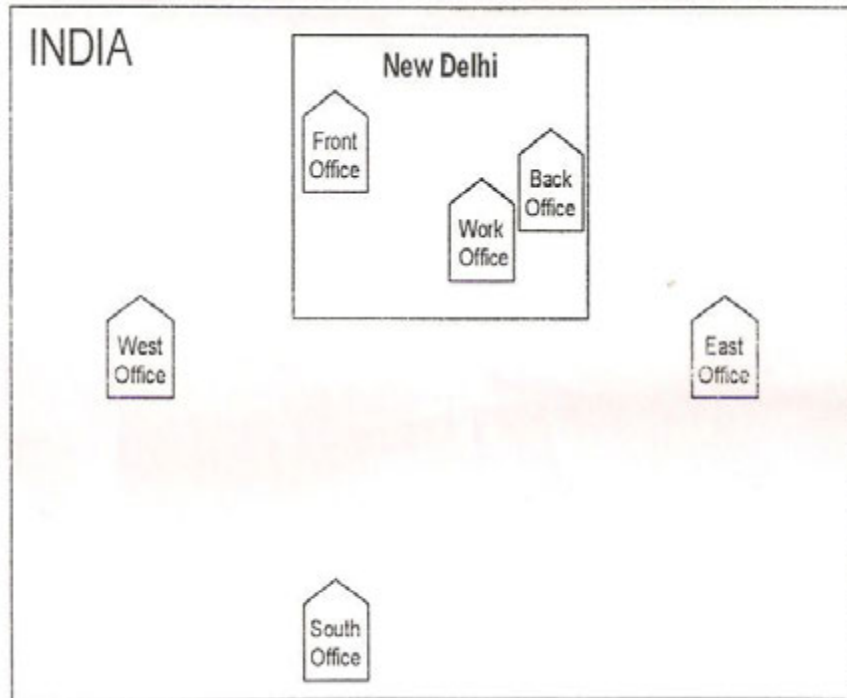

Approximate distances between these offices as per network survey team is as follows :

Place From	Place To	Distance
Back Office	Front Office	10km
Back Office	Work Office	70 Meter
Back Office	East Office	1291km
Back Office	West Office	790 km
Back Office	South Office	1952 km

In continuation of the above , the company experts have planned to install the following number of computers in each of their offices :

Front Office	100
Work Office	20
East Office	50
West Office	50

South Office	50
	50

- (1) Suggest network types (out of LAN , MAN, WAN) for connecting each of the following set of their offices :
  - Back Office and Work Office
  - Back Office and South Office
- (2) Which device you will suggest to be procured by the company for connecting all the computers with in each of their offices out of the following devices?
  - Switch/Hub
  - Modem
  - Telephone
- (3) Which of the following communication medium, you will suggest to be procured by the company for connecting their local offices in New Delhi for every effective and fast communication?
  - Telephone Cable
  - Optical Fiber
  - Ethernet Cable
- (4) Suggest a cable/wiring layout for connecting the company’s local offices located in New Delhi. Also, suggest an effective method/technology for connecting the company’s regional offices – “East Office”, “West Office” and “South Office” with Offices located in New Delhi.

3. Amaron and company has a setup of office buildings in their campus for networking:  
The distances between the given offices are as under:

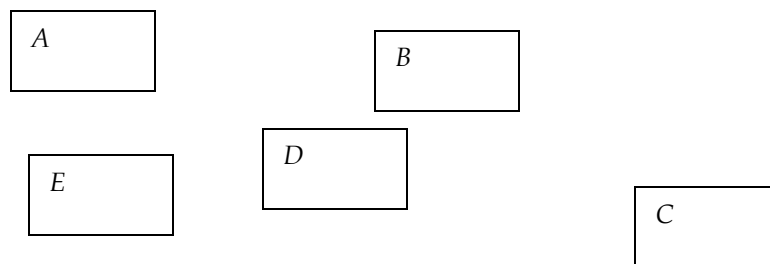

A to B : 40m, A to C : 120m, A to D : 60m, A to E : 45m  
 B to C : 60m, B to D : 90m, B to E : 80m, C to D : 90m  
 C to E : 130m, D to E : 55m

The number of Computers at various offices are:

A : 150, B : 180, C : 200, D : 45, E : 80

- i) Suggest probable cable layout of connection between the buildings.
- ii) Suggest the most suitable place to house the Server. Write valid reason for doing the same.
- iii) Suggest the placement of Repeater, Switch and modem in the network.

- iv) The Company has to establish a communication link between server and a Customer care center located about 3.5km from the campus. Suggest the best possible wired communication link between the two offices.
4. “Hindustan Connecting World Association” is planning to start their offices in four major cities in India to provide regional IT infrastructure support in the field of Education & Culture. The company has planned to set up their head office in New Delhi in three locations and have named their New Delhi offices as “Sales Office”, ”Head Office” and “Tech Office”. The company’s regional offices are located at ”Coimbatore”, “Kolkata” and “Ahmedabad”.
- A rough layout of the same is as follows :
- Approximate distances between these offices as per network survey team is as follows :
- | Place From  | Place To          | Distance |
|-------------|-------------------|----------|
| Head Office | Sales Office      | 10 KM    |
| Head Office | Tech Office       | 70 Meter |
| Head Office | Kolkata Office    | 1291 KM  |
| Head Office | Ahmedabad Office  | 790 KM   |
| Head Office | Coimbatore Office | 1952 KM  |
- In continuation of the above, the company experts have planned to install the following number of computers in each of their offices :
- |                   |     |
|-------------------|-----|
| Head Office       | 100 |
| Sales Office      | 20  |
| Tech Office       | 50  |
| Kolkata Office    | 50  |
| Ahmedabad Office  | 50  |
| Coimbatore Office | 50  |
- (i) Suggest network type (out of LAN, MAN, WAN) for connecting each of the following set of their offices :
- Head Office and Tech Office
  - Head Office and Coimbatore Office
- (ii) Which device will you suggest to be procured by the company for connecting all the computers within each of, their offices out of the following devices ?
- Modem
  - Telephone
  - Switch/Hub
- (iii) Which of the following communication media, will you suggest to be procured by the company for connecting their local offices in New Delhi for very effective and fast communication ?
- Ethernet Cable
  - Optical Fiber
  - Telephone Cable
- (v) Suggest a cable/wiring layout for connecting the company’s local offices located in New Delhi. Also,, suggest an effective method/technology for connecting the company’s regional offices at “Kolkata”, “Coimbatore” and “Ahmedabad”.

**PRACTICAL QUESTIONS**

1. Questions related to Arrays  
Examples :
  - (a) Write a program to merge two given arrays, A in ascending order, B in descending order into third array C in ascending order.
  - (b) Write a program to sort elements of a one dimensional array using Insertion sort.
  - (c) Write a program to sort elements of a one dimensional array using Bubble sort.
  - (d) Write a program to sort element of a single dimensional array using selection sort.
2. Questions related to Link List, Stack and Queue  
Examples :
  - (a) Write a menu driven program to implement stack using link list.
  - (b) Write a menu driven program to implement queue using link list.
3. Questions related to File Handling  
Examples :
  - (a) Write a menu driven program in C++ to create a binary file "BOOK.DAT" which contains details like Bookno, Bookname, Price and no of pages. Write functions to perform following operations on it :
    - i) Append record ii) Modify a record for a given book no. iii) Delete a record for a given book no iv) Display all list of records.
  - (b) Write a program to input the name of a text file from the user and display:
    - (i) The number of blanks present.
    - (ii) The number of lines present.
    - (iii) The number of capital alphabets present.
    - (iv) The number of small alphabets present.
    - (v) The number of lines starting with a capital alphabet.
    - (vi) The number of words present.
    - (vii) The number of digits present.
    - (viii) The number of words ending with a vowel.
  - (c) A blood bank maintains a data file that contains the following information for every donor: Name, Date of Birth, Telephone number, Blood group. Write a program in C++ to do the following:
    - i) Given a blood group, display name, date of birth and phone number of all the persons of the given blood group.
    - ii) Append records in the file.
    - iii) Input a telephone number and modify the corresponding record.
4. SQL (05 Marks)  
Examples :
 

(A) Write SQL command for (a ) to (e) on the basis of table FURNITURE.

**Table: FURNITURE**

<b>No.</b>	<b>ITEMNAME</b>	<b>TYPE</b>	<b>DATEOFSTOCK</b>	<b>PRICE</b>	<b>DISCOUNT</b>
1	White lotus	Double Bed	2002-02-23	30000	25

2	<i>Pink feather</i>	<i>Baby cot</i>	<i>2002-01-20</i>	<i>7000</i>	<i>20</i>
3	<i>Dolphin</i>	<i>Baby cot</i>	<i>2002-02-19</i>	<i>9500</i>	<i>20</i>
4	<i>Decent</i>	<i>Office Table</i>	<i>2002-01-01</i>	<i>25000</i>	<i>30</i>
5	<i>Comfort zone</i>	<i>Double Bed</i>	<i>2002-01-12</i>	<i>25000</i>	<i>25</i>
6	<i>Donald</i>	<i>Baby cot</i>	<i>2002-02-24</i>	<i>6500</i>	<i>15</i>
7	<i>Royal Finish</i>	<i>Office Table</i>	<i>2002-02-20</i>	<i>18000</i>	<i>30</i>
8	<i>Royal tiger</i>	<i>Sofa</i>	<i>2002-02-22</i>	<i>31000</i>	<i>30</i>
9	<i>Econo sitting</i>	<i>Sofa</i>	<i>2001-12-13</i>	<i>9500</i>	<i>25</i>
10	<i>Eating Paradise</i>	<i>Dining Table</i>	<i>2002-02-19</i>	<i>11500</i>	<i>25</i>

- (a) To show all information about the Baby cots from the FURNITURE table.
- (b) To list the ITEMNAME which are priced at more than 15000 from the FURNITURE table.
- (c) To display ITEMNAME and DATEOFSTOCK of those items, in which the DISCOUNT percentage is more than 25 from FURNITURE table.
- (e) To count the number of items, whose TYPE is 'Sofa' from FURNITURE table.
- (f) Give the output of SQL statement :
- Select Max(Discount) from Furniture;*
- (B) Write SQL command for (a) to (e) on the basis of table GARMENT.

**Table: GARMENT**

<b>GCODE</b>	<b>Description</b>	<b>Price</b>	<b>FCODE</b>	<b>READYDATE</b>
<i>10023</i>	<i>PENCIL SKIRT</i>	<i>1150</i>	<i>F03</i>	<i>2008-12-19</i>
<i>10001</i>	<i>FORMAL SHIRT</i>	<i>1250</i>	<i>F01</i>	<i>2008-01-12</i>
<i>10012</i>	<i>INFORMAL SHIRT</i>	<i>1550</i>	<i>F02</i>	<i>2008-06-06</i>
<i>10024</i>	<i>BABY TOP</i>	<i>750</i>	<i>F03</i>	<i>2007-04-07</i>

10090	TULIP SKIRT	850	F02	2007-03-31
10019	EVENING GOWN	850	F03	2008-06-06
10009	INFORMAL PANT	1500	F02	2008-10-20
10007	FORMAL PANT	1350	F01	2008-03-09
10020	FROCK	850	F04	2007-09-09
10089	SLACKS	750	F03	2008-10-31

- (a) To show all information about the BABY TOP from the GARMENT table.  
 (b) To display GCODE and DESCRIPTION of each GARMENT in descending order of GCODE.  
 (c) To display the average PRICE of all the GARMENTS, which are made up of FABRIC with FCODE as F03.  
 (d) To display FABRIC wise highest and lowest price of GARMENTS from GARMENT table.  
 (e) Give the output of SQL statement :  
 Select Sum(Price) from Garment where FCODE='F01';

5. Questions related to reduction of expression using K-MAP

Examples:

- (a) Reduce the following Boolean expression using K-map and draw the digital circuit design. 02 Marks

$$F(A,B,C,D) = \prod (0,1,3,5,6,7,10,14,15)$$

- (b) Reduce the following Boolean expression using K-map and draw the digital circuit design. 02 Marks

$$F(A,B,C,D) = \sum (0,2,3,5,7,8,10,13,15)$$

KENDRIYA VIDYALAYA SANGATHAN  
AHMEDABAD REGION

SURE SHORT QUESTIONS ANSWERS – MINIMUM LEVEL UPTO 50%

CLASS : XII

SUBJECT : COMPUTER SCIENCE

Prepared by : Raval Vishnu, PGT(Computer Science)  
Kendriya Vidyalaya CRPF, Gandhinagar

Q 1 (a) 2 Marks Theory Questions

1. Inline functions are defined with the help of inline keyword and the inline function takes the format as a normal function but when it is compiled it is compiled as inline code. The function is placed separately as inline function, thus adding readability to the source program. When the program is compiled, the code present in function body is replaced in the place of function call.

```
#include <iostream.h>
int exforsys(int);
void main()
{
    int x;
    cout << "\n Enter the Input Value: ";
    cin >> x;
    cout << "\n The Output is: " << exforsys(x);
}
inline int exforsys(int x1)
{
    return 5*x1;
}
```

2. Run time error: error occurring in a program during its execution. Program execution halts when such error is encountered .

**Example :**

```
int A,B,C;
cin >> A >> B;
C=A/B; //Run time error if value of b is zero.
```

**Syntax error :**

Error occurred due to wrong syntax of language deducted by the compiler during compilation.

**Example :**

```
cout >> "a c++ program";
```

3. **Type Casting:** It is an explicit process of conversion of a data from one type to another.

It is user defined forced conversion. It is also known as explicit type conversion. It is done with the help of casting operator ().

For example

```
int A=1, B=2;
float C = (float)A/B; //Type Casting
cout<<C;
```

OUTPUT:

0.5

4. A class provides three access labels private, protected and public. A member declared as private or protected remains hidden from outside world and it can only be access by the member functions of the class. A member declared as public is made available to the outside the world.
5. The member function of every object have access a sort of magic pointer name this which point to the object itself. Thus any member function can find out the address of the object of which it is a member.

The this pointer represents an objects that invokes a member function. It stores the address of the object that is invoking a member function and it (this pointer.) is an implicit argument to the member function being invoked.

The this pointer is useful in returning the objects address of which the function is a member.

6. A local variable is a variable which is declared inside function or block statement. A global variable is a vriable which is declared outside all the functions. A local variable is accessible within its block in which it is declared but a global variable is accessible in whole program.

Example :

```
#include<iostream.h>
#include<conio.h>
int a=7; //global variable
void main( )
{
    int b=6; //local variable
    cout<<a<<b;
}
```

### Q 1 (a) 1 Mark Header Files Questions

1. stdio.h
- string.h
2. iostream.h
- math.h
3. iostream.h
- math.h
4. ctype.h
- iostream.h

- 5. iostream.h  
iomanip.h

**Q 1 (c) 21 Marks Error finding Questions**

```
1. #include<iostream.h>

    struct Pix
    {      int Color, Style ;
    };
    void ShowPoint(Pix P)
    {      cout<<P.Color<<P.Style<<endl;
    }
    void main()
    {      Pix Point1 = {5,3};
           ShowPoint(Point1);
           Pix Point2 = Point1;
           Point1.Color+=2;
           ShowPoint(Point2);
    }
```

```
2. #include<iostream.h>

class Student
{
    int num;
    char name[10 ];
public:
    void getdata(){
        cin>>num;
        cin.getline(name);
    }
};
void main()
{
    Student obj;
    obj.getdata();
}
```

```
3. #include<iostream.h>
const int multiple=3;
void main( )
{
    int value=15;
    for(int c=0;c<=5;c++,value-=2)
        if(value%multiple= 0)
```

```

        cout<<value*multiple;
        cout<<endl;
    else
        cout<<value+multiple<<endl;
}

```

**Q 1 (d) & (e) 2 Marks Output Finding Questions**

1. PROGRAMMING LANGUAGE C++24
2. 13:17:10
3. 3,30  
7,3  
  
4,40  
4,3
4. 50 50  
50 70  
25 50
5. cOMMuTEE

**Q 1 (f) 2 Marks Random Number Questions**

1. Correct Answer is either (ii) CHN:KOL:CHN: or (iv) KOL:CHN:KOL:
2. (iii) 14:13:11:11:

i	P	random(p)+low	
		Minimum	Maximum
1	5	10	14
2	4	10	13
3	3	10	12
4	2	10	11

The only option that satisfies these values is option (iii).

3. Maximum Value:- 19  
Minimum Value:- 10
4. Option (iii) is correct.

**Q2 (a) 2 Marks Theory Questions**

1. The **this** pointer is a pointer accessible only within the nonstatic member functions of a **class, struct, or union** type. It points to the object for which the member function is called. Static member functions do not have a **this** pointer.

e.g this

this->member-identifier

## 2. Constructor :

- i. Name of the constructor functions is same as the name of the class.
- ii. No return type required for constructor functions.
- iii. Constructor functions are called automatically at the time of creation of the object.
- iv. Constructor can be overloaded.
- v. constructor functions are defined in public.

### **Destructor :**

- i. Name of the destructor is same as the name of the class preceded by ~.
- ii. No return type required for destructor function.
- iii. Destructor functions are called automatically when the scope of the object gets over.
- iv. Destructor can not be overloaded.
- v. Destructor function is defined in public.

3. Polymorphism : It is the property by which the same message can be sent to objects of several different classes, and each object can respond to it in a different way depending upon its class. In C++ it is implemented through Function Overloading/ Constructor Overloading.

Example :

```
float area(float a)
{
    Return a*a;
}
```

```
float area(float a, float b)
{
    Return a*b;
}
```

### **Q2 (b) 2 Marks Constructor & Destructor Questions**

1. i) constructor overloading  
AirIndia A1;  
AirIndia("1001",100);
- ii) *Destructor*. It is automatically invoked when an object of class goes out of scope.
2. i) It is referred as destructor. It is automatically invoked when an object of class goes out of scope.
- ii) It is referred as constructor. It is automatically invoked when an object of class is declared / created.

- iii) It is parameterized constructor and gets invoked when an object of class is created / declared with the matched parameters.
  - iv) 

```
testmeout ob1(15, "Vicky");
testmeout (testmeout & t)
{
    rollno=t.rollno;
}
```
  - v) output will be :  
1 is appearing for examination  
1 is attempting questions  
1 is Leaving examination hall
  - vi) It is constructor overloading. It shows Polymorphism feature of the OOP.
3. (i) Function 1: Constructor  
Function 2 : Destructor
- (ii) Function 1 is executed or invoked automatically when an object of class Maths is created.  
Function 2 is invoked automatically when the scope of an object of class Maths comes to an end.
4. i) Object created  
ii) 

```
Master(Master &o)
{
    strcpy(name, o.name);
}
```

**Q2 (c) 4 Marks Class Define Questions**

1. class Train

```
{
    int TrainNumber;
    float distance, fuel;
    char destination[30];
    void CALFUEL()
    {
        if(distance<=1500)
            fuel=250;
        else if (distance>1500 && distance<=3000)
            fuel=1000;
        else
            fuel=2500;
    }
public:
    void FEEDINFO()
    {
        cout<<"Enter detail of the train"<<endl;
        cin>>TrainNumber>>distance;
        gets(destination);
        CALFUEL();
    }
}
```

```

    }
    void SHOWINFO( )
    {
        cout<< TrainNumber<<distance<<fuel;
        puts(destination);
    }
};

```

```

2. class tour
{
    int tcode,adults,children,distance;
    float totalfare;
    void assignfare()
    {
        float cfare=50, afare=1500;
        if(distance<1500)
            afare=afareshare-(afareshare*25/100);
        totalfare=(children*cfare)+(adults*afareshare);
    }
public:
    travel()
    {
        tcode=adults=children=distance=totalfare=0; }
    void entertour()
    {
        do
        {
            cout<<"Enter tcode between 6-10 ";
            cin>>tcode;
            if (tcode<6 || tcode>10)
                cout<<"Invalid tcode "<<endl;
        }while(tcode<6 || tcode>10);
        cout<<"Enter children, adults, distance";
        cin>>children>>adults>>distance;
        assignfare();
    }
    void showtour()
    {
        cout<<"tcode:"<<tcode<<endl;
        cout<<"children:"<<children<<endl;
        cout<<"adults :"<<adults<<endl;
        cout<<"distance:"<<distance<<endl;
        cout<<"total fare:"<<totalfare<<endl;
    }
};

```

```

3. class BOOK
{
    int Bookno;

```

```

        char Title[20];
        float Price;
        float Total_cost(int N)
        {
            return(N*price);
        }
public:
    void input()
    {
        cout<<"Input bookno, title, price";
        cin>>Bookno>>Title>>Price;
    }
    void purchase()
    {
        int n;
        float tcost;
        cout<< "Input no of copies";
        cin>>n;
        tcost=Total_cost(n);
        cout<<tcost;
    }
};

```

```

4. class Teacher
{
    private :
    char Name[20],Subject10];
    float Basic, DA, HRA, Salary;
    float Calculate()
    {
        return (Basic+DA+HRA);.
    }
public:
    void Readdata()
    {
        cout<<"enter the name and Subject of the teacher";
        gets(Name);
        gets(Subject);
        cout<<"enter the basic, da and hra";
        cin>>Basic>>DA>>HRA;
        Salary=Calculate();
    }
    void displaydata()
    {
        cout<<"Name"<<Name<<endl;

```

```

        cout<<"Subject"<<Subject<<endl;
        cout<<"Basic"<<Basic<<endl;
        cout<<"DA"<<DA<<endl;
        cout<<"HRA"<<HRA<<endl;
        cout<<"Salary"<<Salary;
    }
};

```

```

5. class Item
{
    int item_no ;
    float price;
    char Item_name[20];
    float total_cost(int N)
    {
        float t;
        t=N*price
        return t;
    }
public:
    void input()
    {
        cin>> Item_no >>price;
        gets(Item_name);
    }
    void purchase()
    {
        int n;
        float Totalcost;
        cout<<"Enter no. of items to be purchased :";
        cin>>n;
        Totalcost=total_cost(n);
        cout<<"Total Cost = "<<Totalcost;
    }
};

```

### **Q2 (d) 4 Marks Inheritance Questions**

1. (i) Nil
- (ii) void enter( );  
void show( );
- (iii) Member Functions : void sales\_entry( );  
void sales\_detail( );  
void Register( );  
void status( );  
void enter( );  
void show( );

Data Members : voucher\_no, sales\_date, salary

(iv) 66

2. (i) **Multiple Inheritance**  
(ii) None

**Or**

All the above functions can be called.

- (iii) DATA MEMBERS : ICode, IName, Attendance, Grade, remuneration  
MEMBER FUNCTIONS : IEntry( ), IDisplay( ), LEntry( ), LDisplay( ),  
assignrem( ), TEntry( ), TDisplay( )

(iv) IEntry( ), IDisplay( )

3. i) Multilevel Inheritance  
ii) None / No data members  
iii) 56  
iv) s\_no, s\_name[20], rating

4. (i) Data Members - None  
Member functions - Read\_pri\_details(), Disp\_pri\_details().  
(ii) 29 Bytes  
(iii) Member functions- read\_detail(), disp\_detail(), read\_off\_details(),  
disp\_off\_details(), read\_pri\_details(), disp\_pri\_details().

5. (i) MNC  
(ii) 129 Bytes  
(iii)  
MNC::enterdata(), MNC::dispalydata(), branch::add(), branch::show(), outlet::Enter()  
Outlet::output()  
(iv) MNC::country

**Q3 (a) & (d) 1 D / 2 D Array Questions**

1. void resultant(int x[ ], int n )  
{  
    int y[10], c[10], k=0, j=0;  
    for(int i = 0; i<n ;i++)  
    {  
        if( x[i] < 0)  
        {     y[j]=x[i];  
            j=j+1;  
        }  
        else  
        {     c[k]=x[i];

```

        k=k+1;
    }
}
for(i=0;i<j; i++)
{
    x[i]=y[i];
}
for(int l=0;l<k;l++)
{
    x[i]=c[l];
    i=i+1;
}
for( i= 0; i<n ;i++)
{
    cout<<x[i];
}
}

```

2. void replace(int Arr[ ], int size)

```

{
    for (int i=0; i<size; i++)
    if(Arr[i] % 2 != 0)
        Arr[i] * = 3;
    else
        Arr[i] * = 2;

    cout<<"Array after change :";
    for (int i=0; i<size; i++)
        cout<<Arr[i];
}

```

3. void swap(int b[6], int size)

```

{
    int r=size/2, i=r, k, temp;
    for(k=0;k<r;k++)
    {
        temp=b[k];
        b[k]=b[i];
        b[i]=temp;
        i++;
    }
    cout<<"Array after swap : ";
    for(k=0;k<size;k++)
    {
        cout<<b[k];
    }
}

```

4. `void sumarr(int a[10][10], int row, int col)`
- ```

{
    int i, j, sum1= 0,sum2= 0;
    for(i=0;i<row;i++)
    {
        for(j=0;j<col;j++)
        {
            if (i==j)
                sum1=sum1+a[i][j];
            if(i+j==row-1)
                sum2=sum2+a[i][j];
        }
    }
    cout<<"sum of left diagonal = "<<sum1;
    cout<<"\nSum of right diagonal = "<<sum2;
}

```
5. `void show(int x[10][10], int n)`
- ```

{
    int s1=0,s2=0; int i=n/2;
    // for the sum of rows
    for(int j=0;j<n;j++)
    { if (x[i][j]>0)
        S1+=x[i][j];
    }
    cout<< "\nTum of all positive elements of the middle row"<<s1;
    // for the sum of columns
    for(int j=0;j<n;j++)
    { if (x[j][i]<0)
        s2+=x[j][i];
    }
    cout<<" \nSum of all negative elements of middle column"<<s2;
}

```
6. `void func(int arr[], int size)`
- ```

{
    int a2[20][20], i, j;
    for (i=0;i<size; i++)
        {
            for (j=0;j<size;j++)
                {
                    if ((i+j) >=size)
                        a2[i][j]=0;
                    else a2[i][j]= arr[j];
                    cout<<a2[i][j]<<" ";
                }
            cout<<"\n";
        }
}

```
7. `void display_diagonals(int MATRIX[10][10], int r, int c)`

```

{
    clrscr();
    // Finding the diagonal from left index to right
    cout << "Diagonal One : ";
    for(int i=0; i<r; i++)
        for(int j=0; j<c; j++)
            {
                cout << MATRIX[i][j] << " ";
                i++;
            }
        cout << endl;
    // Finding the diagonal from right index to left
    cout << "Diagonal Two : ";
    for(i=0; i<=r; i++)
        {
            for(int j=c-1; j>=0; j--)
                {
                    cout << MATRIX[i][j] << " ";
                    i++;
                }
        }
    getch();
}

```

```

8. void display_RowCol(int Array[10][10], int r, int c)
{
    int row = r / 2;
    int col = c / 2;
    // Finding the middle row
    cout << "Middle Row : ";
    for(int j=0; j<c; j++)
        cout << Array[row][j] << " ";
    cout << endl;
    // Finding the middle column
    cout << "Middle Column : ";
    for(j=0; j<c; j++)
        cout << Array[j][col] << " ";
    getch();
}

```

### Q3 (b) Address Finding Questions

1.  $m=15, n=35$

$W=8$  byte

Address of  $[I, J]$  th element =  $B + W((I-L1)+m(J-L2))$

$B$ =Address of  $[I, J]$  th element -  $W((I-L1)+m(J-L2))$

$$B = \text{Address of } [5,10] \text{ th element} - 8((5-0)+15(10-0))$$

$$B = 4000 - 8(5+15(10-0))$$

$$B = 4000 - 8(5+15(10))$$

$$B = 4000 - 8(5+150)$$

$$B = 4000 - 8(155)$$

$$B = 4000 - 1240$$

$$B = 2760$$

$$\text{Address of } [I,J] \text{ th element} = B + W((I-L_1)+m(J-L_2))$$

$$\text{Address of } [2,5] \text{ th element} = 2760 + 8((2-0)+15(5-0))$$

$$\text{Address of } [2,5] \text{ th element} = 2760 + 8(2+15(5-0))$$

$$\text{Address of } [2,5] \text{ th element} = 2760 + 8(2+15(5))$$

$$\text{Address of } [2,5] \text{ th element} = 2760 + 8(2+75)$$

$$\text{Address of } [2,5] \text{ th element} = 2760 + 8(77)$$

$$\text{Address of } [2,5] \text{ th element} = 2760 + 616$$

$$\text{Address of } [2,5] \text{ th element} = 3376$$

2. Address of Array[i][j] along the column =  
Base Address + W[(i-L<sub>1</sub>) + (j-L<sub>2</sub>) \* M]

Where

$$W = \text{size of each location in bytes} = 8$$

$$L_1 = \text{Lower Bound of rows} = 0$$

$$L_2 = \text{Lower Bound of columns} = 0$$

$$M = \text{Number of rows per column} = 20$$

$$\text{Address of Array}[4][5] = \text{Base Address} + 8[(4-0) + (5-0) * 20]$$

$$1000 = \text{Base Address} + 8[104]$$

$$\text{Base Address} = 1000 - 8 * 104$$

$$= 1000 - 832$$

$$= 168$$

$$\text{Address of Array}[2][3] = 168 + 8 [(2-0) + (3-0) * 20]$$

$$= 168 + 8 * 62$$

$$= 168 + 496 = 664$$

3.  $n=60, I=20, J=30, B=1800, r=30, Lr=0, Lc=0$   
 Address of  $[I,J]$  th element =  $B + W(n(I-Lr)+(J-Lc))$   
 Address of  $[20,30]$  th element =  $1800+2(60(20-0)+(30-0))$   
 Address of  $[20,30]$  th element =  $1800+2(60(20)+(30))$   
 Address of  $[20,30]$  th element =  $1800+2(1200+(30))$   
 Address of  $[20,30]$  th element =  $1800+2(1230)$   
 Address of  $[20,30]$  th element =  $1800+2460$   
 Address of  $[20,30]$  th element =  $4260$

4. Base Address  $B=2000$   
 Taking default word size( $W$ ) as it is not given  $W=1$   
 First row number  $Lr=1$   
 First column number  $Lc=1$   
 No of columns  $n=4$   
 Now using the formula  $(I,J) = B+W(n(I-Lr)+(J-Lc))$   
 $A(4,4) = 2000+1(4(4-1)+(4-1))$   
 $= 2000+1(4(3+3))$   
 $= 2000+1(12+3)$   
 $= 2000+15$   
 $= 2015$

5.  $B = 1000 \quad W=1$   
 $r = 20 - (-15) + 1 = 36, \quad lr = -15, \quad lc = 20$   
 Address of  $a[0,40] = 1000 + 1[(0-(-15)) + 36(40-20)]$   
 $= 1735$

**Q3 (e) 2 Marks Evaluation of Postfix Expression Questions**

1) Evaluate post fix expression

Expr=3 2 6 \* 4 / + 3 -

| Step | Input Symbol | Stack | Output   |
|------|--------------|-------|----------|
| 1    | 3            | 3     |          |
| 2    | 2            | 3,2   |          |
| 3    | 6            | 3,2,6 |          |
| 4    | *            | 3     | $2*6=12$ |
| 5    | Push 12      | 3,12  |          |

|    |        |        |           |
|----|--------|--------|-----------|
| 6  | 4      | 3,12,4 |           |
| 7  | /      | 3      | $12/4=3$  |
| 8  | Push 3 | 3,3    |           |
| 9  | +      | 6      | $3+3=6$   |
| 10 | 3      | 6,3    |           |
| 11 | -      |        | $6-3=3$   |
| 12 | Push 3 | 3      |           |
| 13 | Empty  | Empty  | 3(Result) |

2. 30, 25, +, 20, 10, -, 12, +, \*

| Step | Element Scanned | Stack    | Intermediate Result |
|------|-----------------|----------|---------------------|
| 1    | 30              | 30       |                     |
| 2    | 25              | 30,25    |                     |
| 3    | +               | -        | $30+25=55$          |
| 4    | Push 55         | 55       |                     |
| 5    | 20              | 55,20    |                     |
| 6    | 10              | 55,20,10 |                     |
| 7    | -               | 55       | $20-10=10$          |
| 8    | Push 10         | 55,10    |                     |
| 9    | 12              | 55,10,12 |                     |
| 10   | +               | 55       | $10+12=22$          |
| 11   | Push 22         | 55,22    |                     |
| 12   | *               | -        | $55*22=1210$        |
| 13   | Push 1210       | 1210     |                     |
| 14   | Empty           | Empty    | 1210 (result)       |

3. 5,6,2,+,\* ,12,4,/,-

| Step | Input   | stack   | Output        |
|------|---------|---------|---------------|
| 1    | 5 push  | 5       |               |
| 2    | 6 push  | 5,6     |               |
| 3    | 2 push  | 5,6,2   |               |
| 4    | + pop   | 5       | $6 + 2 = 8$   |
| 5    | Push 8  | 5,8     |               |
| 6    | * pop   | Empty   | $5 * 8 = 40$  |
| 7    | Push 40 | 40      |               |
| 8    | 12 push | 40,12   |               |
| 9    | 4 push  | 40,12,4 |               |
| 10   | / pop   | 40      | $12/4 = 3$    |
| 11   | Push 3  | 40,3    |               |
| 12   | - pop   | Empty   | $40 - 3 = 37$ |
| 13   | Push 37 | 37      |               |
| 14   | Empty   | empty   | 37(result)    |

**Q4 (b) 2 Marks File Handling Questions**

1. void count( )

```

{ int c=0; char ch;
  ifstream inf;
  inf.open("Joke.TXT",ios::in);
  while(!inf.eof())
  {   inf.get(ch);
      if(ch= =' ');
      c=c+1;
  }
  cout<<c;
  inf.close( );
}

```

```
2. void countis( )
{
    ifstream Fil;
    Fil.open("Dialogue.txt");
    char Word[50];
    int Count=0;
    while (!Fil.eof( ))
    {
        Fil>>Word;
        if(strcmpi(Word,"is")==0)
            count++;
    }
    cout<<count;
    Fil.close( );
}
```

### **Q 5 (a) 2 Marks DBMS Theory Questions**

1. There are three different types of database system users, differentiated by the way they expect to interact with the system.
  - (i) End User : An end user is a person who is not a computer trained person but uses the database to retrieve some information.
  - (ii) Application system analyst : This user is concerned about all of the database at logical level i.e., what all data constitutes the database? What are the relationships between the data-entities etc. without considering the physical implementation details.
  - (iii) Physical storage system analyst : This user is concerned with the physical implementation details of the database such as which storage device, which storage technique should be used? Etc.
2. A non key attribute, whose value are derived from the primary key of some other table, is known as foreign key in the current table.

It is used to represent the relationship between two tables.

The table in which this non-key attribute i.e. foreign key attribute exists, is called a foreign table.

3. Tuples: The rows of tables (relations) are generally referred to as tuples.

Attribute: The columns of tables are generally referred to as attribute.

4. Degree: The number of attributes in a relation determines the degree of a relation. A relation having 3 attributes is said to be a relation of degree 3.

Cardinality: The number of rows in a relation is known as Cardinality.

5. The DDL (Data Definition Language) provides commands for defining relation schemas, deleting relations, creating indexes and modifying relation schemas.

The DML (data Manipulation Language ) includes a query language to insert, delete and modify tuples in the database.

DML is used to put values and manipulate them in tables and other database objects and DDL is used to create tables and other database objects.

6. The HAVING clause places the condition on group but WHERE clause places the condition on individual rows
7. Constraints are used to enforce rules at table level whenever row is inserted, updated/deleted from table.

Constraints can be defined to one of the Two level.

Column Level: Reference to a single column. can be defined any type of integrity.

Table Level: References one or more columns and is defined separately from definition of the columns in the table.

8. Primary key : It is a set of one or more attributes that can uniquely identify tuples within the relation.  
Alternate key : All candidate keys, which are not the primary key of the table are called alternate keys.
9. (i) InternalLevel (Physical level) : This level describes how the data is actually stored on the storage medium. At this level, complex low-level data structures are described in details.  
(ii) Conceptual Level : This level describes what data are actually stored in the database. It also describes the relationships existing among data. At this level, the database is logically in terms of simple data – structures.  
(iii) External Level (View Level) : This level is concerned with the way the data is viewed by individual users. Only a part of the database relevant to the user(s) is provided to them through this level.
10. Degree : No. of attributes in a relation are called its degree.

Cardinality : No. of rows in a relation are called its cardinality.

Example :

| Ino | Item      | Quantity |
|-----|-----------|----------|
| 101 | Pen Drive | 560      |
| 102 | CD        | 749      |

Degree : 03

Cardinality : 02

**Q 5 (b) 6 Marks SQL Questions**

1.

- (b) Select book\_name, author\_name, price from book where publisher='First Publ';
- (c) Select book\_name from book where type='Text';
- (d) Select book\_name, price from books Order by Price;
- (e) Update book set price=price+50 where publishers='EPB';
- (f) Select a.book\_id,a.book\_name,b.quantity\_issued from book a, issued b where a.book\_id=b.book\_id
- (g) Insert into issued Values ('F0003',1);
  - i. 5
  - ii. 750
  - iii. The Tears                      William Hopkins  
Thunderbolts                      Anna Roberts
  - iv. 1

2.

- (i) select firstname, lastname, address, city from employees where city='Paris';
- (ii) select \* from employees order by firstname desc;
- (iii) select employees.firstname, employees.lastname, empsalary.salary + empsalary.benefits total\_salary from employees, empsalary where employees.empid=empsalary.empid and designation='Manager';
- (iv) select max(salary) from empsalary where designation in('Manager','Clerk');
- (v) (i)

| <u>FIRSTNAME</u> | <u>SALARY</u> |
|------------------|---------------|
| Rachel           | 32000         |
| Peter            | 28000         |

  - (ii)

| <u>COUNT(DISTINCT DESIGNATION)</u> |
|------------------------------------|
| 4                                  |
  - (iii)

| <u>DESIGNATION</u> | <u>SUM(SALARY)</u> |
|--------------------|--------------------|
| Clerk              | 135000             |
| Manager            | 215000             |
  - (iv) SUM(BENEFITS)  
32000

3.

- (i) SELECT sendername from Sender where sendercity='Mumbai';
- (ii) Select R.RecIC, S.Sendername, S.SenderAddress, R.RecName, R.RecAddress from Sender S, Receptient R where S.SenderID=R.SenderID;
- (iii) SELECT \* from Recipient ORDER By RecName;
- (iv) SELECT COUNT( \*) from Recipient Group By RecCity;
- (v) SenderCity  
Mumbai  
New Delhi
- (vi) 

| <u>A.SenderName</u> | <u>B.RecName</u> |
|---------------------|------------------|
| R Jain              | H Singh          |
| S Jha               | P K Swamy        |

|        |                |                      |
|--------|----------------|----------------------|
| (vii)  | <u>RecName</u> | <u>RecAddress</u>    |
|        | S Mahajan      | 116, A Vihar         |
|        | S Tripathi     | 13, BID, Mayur Vihar |
| (viii) | <u>RecID</u>   | <u>RecName</u>       |
|        | ND08           | S Mahajan            |
|        | ND48           | S Tripathi           |

4. (i) Select PNAME, CID, QTY, PRICE from SUPPLIER where DISCOUNT is not NULL;

(ii) Select \* from SUPPLIER where CID='C1' or CID='C2' or CID='C3';

(iii) Select CID, MIN(QTY) from SUPPLIER group by CID;

(iv) Select PNAME, PRICE from SUPPLIER orderby PRICE desc;

(v) PNAME QTY CNAME

Cake 250 Britannia

Chocolate 380 Amul

Sauce 470 Kissan

Maggi 340 Marie

Biscuit 560 Marie

Jam 220 Kissan

(vi) COUNT(\*)

1

1

1

5. (i) SELECT NAME FROM DOCTOR WHERE DEPT='MEDICINE' AND EXPERIENCE>10;

(ii) SELECT AVG(E.Salary=E.BASIC+E.ALLOWANCE) FROM DOCTOR D SALARY E WHERE D.DEPT='ENT' AND D.ID=E.ID;

(iii) SELECT MIN(E.ALLOWANCE) FROM DOCTOR D, SALARY E WHERE D.SEX='F' AND D.ID=E.ID;

(iv) SELECT MAX(E.CONSULTANTION) FROM DOCTOR D, SALARY E WHERE D.SEX='M' AND D.ID=E.ID;

(i) 4

(ii) Name Dept Basic  
John Ent 12000

### Q 6 (a) Boolean Algebra Questions

1. Principle of duality states that from every boolean relation, another boolean realation can be derived by

(i) changing each OR sign(+) to an AND sign(-).

(ii) changing each AND sign(-) to an OR sign(+)

(iii) replacing each 1 by 0 and each 0 by 1.

The new derived relation is known as the dual of the original relation.

Dual of  $A + \bar{A}B$  will be

$$A + \bar{A}B = A \cdot (\bar{A} + B).$$

2. Absorption law states:  
 (i)  $X + XY = X$       (ii)  $X(X + Y) = X$

| Input |   |    | Output   |       | Output   |
|-------|---|----|----------|-------|----------|
| X     | Y | XY | $X + XY$ | $X+Y$ | $X(X+Y)$ |
| 0     | 0 | 0  | 0        | 0     | 0        |
| 0     | 1 | 0  | 0        | 1     | 0        |
| 1     | 0 | 0  | 1        | 1     | 1        |
| 1     | 1 | 1  | 1        | 1     | 1        |

3. If X, Y, Z are Boolean Variables then  
 $X.(Y + Z) = X.Y + X.Z$       or       $X+Y.Z = (X+Y).(X+Z)$

| X | Y | Z | $Y+Z$ | $X.(Y+Z)$ | $X.Y$ | $X.Z$ | $X.Y+X.Z$ |
|---|---|---|-------|-----------|-------|-------|-----------|
| 0 | 0 | 0 | 0     | 0         | 0     | 0     | 0         |
| 0 | 0 | 1 | 1     | 0         | 0     | 0     | 0         |
| 0 | 1 | 0 | 1     | 0         | 0     | 0     | 0         |
| 0 | 1 | 1 | 1     | 0         | 0     | 0     | 0         |
| 1 | 0 | 0 | 0     | 0         | 0     | 0     | 0         |
| 1 | 0 | 1 | 1     | 1         | 0     | 1     | 1         |
| 1 | 1 | 0 | 1     | 1         | 1     | 0     | 1         |
| 1 | 1 | 1 | 1     | 1         | 1     | 1     | 1         |

4.  $X'Y'(Z'+Z)+YZ'(X'+X)+XY'(Z'+Z)$   
 $X'Y'+YZ'+XY'$   
 $Y'(X'+X)+YZ'$   
 $Y'+YZ'$   
 $Y'+Z'$

**Q 6 (b) Logic Circuit Questions**

1.

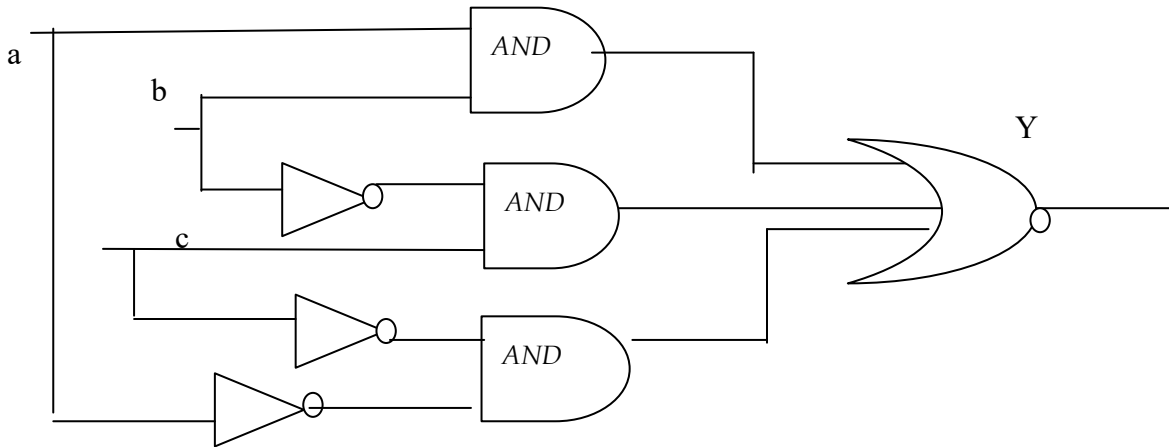

2.

Ans:

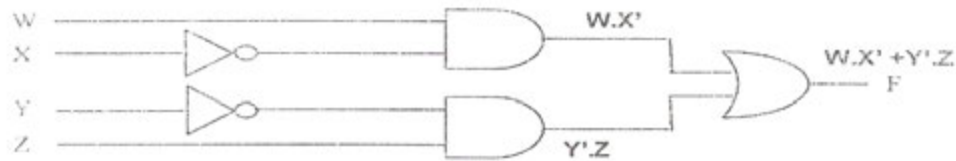

$$F = W.X' + Y'.Z$$

3.  $A+B'+A'+B$

4.  $(AC)' + (BA)' + (BC)'$

**Q 6 1 Mark SOP/POS Questions**

1. The last col. of the truth table gives the value of F for each occurrence of 1's in this col. we get a Minterm correspond to that row. So that

$$F = A'B'C' + A'BC + ABC' + ABC$$

2.  $F(X, Y, Z) = \sum(0, 2, 4, 5)$

$$= X'.Y'.Z' + X'.Y.Z' + X.Y'.Z' + X.Y'.Z$$

3.  $(A+B+C)(A+B'+C)(A'+B+C)(A'+B'+C)(A'+B'+C')$

**Q 6 3 Marks K-Map Questions**

1.  $F(A, B, C, D) = \prod(0, 1, 2, 3, 4, 5, 10, 11, 15)$

|       |       |         |         |         |         |
|-------|-------|---------|---------|---------|---------|
|       |       | CD      |         |         |         |
|       |       | C+D     | C+D'    | C'+D'   | C'+D    |
| AB    | A+B   | 0<br>0  | 0<br>1  | 0<br>3  | 0<br>2  |
|       | A+B'  | 0<br>4  | 0<br>5  | 1<br>7  | 1<br>6  |
| A'+B' | A'+B' | 1<br>12 | 1<br>13 | 0<br>15 | 1<br>14 |
|       | A'+B  | 1<br>8  | 1<br>9  | 0<br>11 | 0<br>10 |

Pair 1 is m11.m15

Quad 1 is m0.m1.m4.m5

Quad 2 is m2.m3.m10.m11

Reduced expression for Pair 1 is  $(A'+C'+D')$

Reduced expression for Quad 1 is  $(A+C)$

Reduced expression for Quad 2 is  $(B+C')$

Hence final POS expression will be

$$F(A,B,C,D) = (A+C).(B+C').(A'+C'+D')$$

2.  $F(P,Q,R,S) = \Sigma(0,3,5,6,7,11,12,15)$

|  |      |      |     |    |     |
|--|------|------|-----|----|-----|
|  |      | RS   |     |    |     |
|  | PQ   | R'S' | R'S | RS | RS' |
|  | P'Q' | 1    | 0   | 1  | 0   |
|  | P'Q  | 0    | 1   | 3  | 2   |
|  | PQ   | 0    | 1   | 1  | 1   |
|  | PQ'  | 1    | 0   | 1  | 0   |
|  |      | 4    | 5   | 7  | 6   |
|  |      | 12   | 13  | 15 | 14  |
|  |      | 0    | 0   | 1  | 0   |
|  |      | 8    | 9   | 11 | 10  |

Quad 1 is (m3+m7+m11+m15)

Pair 1 is (m5+m7)

Pair 2 is (m7+m6)

Block 1 is m0

Block 2 is m12

Reduced expression for Quad 1 is RS

Reduced expression for Pair 1 is P'QS

Reduced expression for Pair 2 is P'QR

Reduced expression for Block 1 is P'Q'R'S'

Reduced expression for Block 2 is PQR'S'

Hence final SOP expression will be

$$F(P,Q,R,S) = RS + P'QS + P'QR + PQR'S' + P'Q'R'S'$$

3.  $F(A,B,C,D) = \prod(0,1,3,5,6,7,10,14,15)$

| AB \ CD | C+D     | C+D'    | C'+D'   | C'+D    |
|---------|---------|---------|---------|---------|
| A+B     | 0<br>0  | 1       | 0       | 3<br>2  |
| A+B'    | 1<br>4  | 0<br>5  | 0<br>7  | 0<br>6  |
| A'+B'   | 1<br>12 | 1<br>13 | 0<br>15 | 0<br>14 |
| A'+B    | 1<br>8  | 1<br>9  | 1<br>11 | 0<br>10 |

Pair 1 is m0.m1

Pair 2 is m10.m14

Quad 1 is m1.m3.m5.m7

Quad 2 is m6.m7.m14.m15

Reduced expression for Pair 1 is  $(A+B+C)$

Reduced expression for Pair 2 is  $(A'+C'+D)$

Reduced expression for Quad 1 is  $(A+D')$

Reduced expression for Quad 2 is  $(B'+C')$

Hence final POS expression will be

$$F(A,B,C,D) = (A+B+C) (A'+C'+D) (A+D') (B'+C')$$

4.  $F(P,Q,R,S) = \sum (0, 1, 2, 3, 4, 10, 11)$

|      | PQ | RS | R'S' | R'S | RS | RS' |
|------|----|----|------|-----|----|-----|
| P'Q' | 1  | 1  | 1    | 1   | 1  | 1   |
| P'Q  | 0  | 1  | 3    | 2   | 0  | 0   |
| PQ   | 4  | 5  | 7    | 6   | 0  | 0   |
| PQ'  | 12 | 13 | 15   | 14  | 0  | 0   |
|      | 0  | 0  | 1    | 1   | 0  | 0   |
|      | 8  | 9  | 11   | 10  | 0  | 0   |

Quad 1 is  $m_0+m_1+m_2+m_3$

Quad 2 is  $m_2+m_3+m_{10}+m_{11}$

Pair 1 is  $m_0+m_4$

Reduced expression for quad 1 is  $P'Q'$

Reduced expression for quad 2 is  $Q'R$

Reduced expression for pair 1 is  $P'R'S'$

Hence final SOP expression will be

$$F(P,Q,R,S) = P'Q' + Q'R + P'R'S'$$

### Q 7 Networking Questions

1. TCP/IP-Transmission Control Protocol/Internet Protocol

XML-Extensive Markup Language,  
 CDMA- Code Division Multiple Access,  
 WLL- Wireless Local Loop,  
 SMTP- Simple mail transfer Protocol.

2. Cookies : It is a small file that a Web server can store on your machine. Its purpose is to allow a Web server to personalize a Web page, depending on whether you have been to the Web site before and what you may have told it during previous sessions.

3. Difference between HTML and XML

In HTML(Hyper Text Markup Language) both tag semantics and the tag set are fixed whereas, XML(eXtensible Markup Language) is a meta-language for describing markup languages, XML provides facility to define tags and the structural relationships between them. All the semantics of an XML document will either be defined by the applications that process them or by stylesheets.

4. A gateway operates at the upper levels of the OSI model and translates information between two completely different network architectures. Routers allow different

networks to communicate with each other. They forward packets from one network to another based on network layer information. A gateway can interpret and translate the different protocols that are used on two distinct networks. Unlike routers that successfully connect networks with protocols that are similar, a gateway perform an application layer conversion of information from one protocol stack to another.

5. Cyberlaw helps prevent Cyber Crime, Hacking, Data Theft, Software Piracy and protects rights of Cyber Users.
6.
  - (i) Code Division Multiple Access
  - (ii) Wireless Local Loop
  - (iii) File Transfer Protocol
  - (iv) Hypertext Markup Language
7. Mbps(Mega Bits Per Second)
8. Hub shares bandwidth, so slower than Switch  
All users connected to a single hub are in the same segment, sharing the hub's bandwidth or data-carrying capacity. As more users are added to a segment, they compete for a finite amount of bandwidth devoted to that segment.  
Switch doesn't share bandwidth, so faster than Hub  
To insulate the transmission from the other ports, the switch establishes a temporary connection between the source and destination and then terminates the connection once the conversation is done.
9. The crackers are the malicious programmers who break into secure systems whereas Hackers are more interested in gaining knowledge about computer systems and possibly using this knowledge for playful pranks.
10. Spam refers to electronic junk mail or junk newsgroups postings. Some people define spam even more generally as any unsolicited e-mail.
11. Mozilla Firefox, Google Chrome, Internet Explorer
12. Virus : It is a malicious program that damages data and files and causes harm to computer system.  
Worms : Worms disrupt services and create system management problems. In some cases worms can install viruses that cause damage to system.
13. It is ageneric term which refers to all the legal and regulatory aspects of Internet and the World Wide Web. Anything concerned with or related to or emanating from any legal aspects or issues concerning any activity of netizens and others, in Cyberspace comes within the ambit of Cyberlaw.
14. Web 2.0 refers to added features and applications to WWW that make the web more interactive, support easy online- information exchange and interoperability. Some noticeable features of web 2.0 are blogs, wikis, video-sharing websites, social networking websites, RSS etc.
15. Open source software can be freely used (source code is available to the customer) but it does not have to be free of charge.  
Proprietary software is the software that is neither open nor freely available (source code is not available, further distribution and modification is either forbidden or requires special permission by the supplier or vendor).
16. Client side : VBScript, JavaScript, PHP  
Server side : PHP, Perl, ASP, JSP

17. Web browser : It is a WWW client that navigates through the World Wide Web and displays web pages.  
Web Server : It is a WWW server that responds to the requests made by web browsers.
18. A URL (Uniform Resource Locator) specifies the distinct address for each resource on the Internet.  
URLs look like  
type://address/path  
Example : <http://www.google.com>
- 19.
- (i) eXtensible Markup Language
  - (ii) Hypertext Markup Language
  - (iii) Global System for Mobile
  - (iv) Wireless Local Loop
  - (v) Point to Point Protocol
  - (vi) Dynamic Hypertext Markup Language
  - (vii) Code Division Multiple Access
  - (viii) Hypertext Transfer Protocol
  - (ix) Uniform Resource Locator
  - (x) Transfer Control Protocol/ Internet Protocol
20. Firewall : It is a system designed to prevent unauthorized access to and from a private network is called a firewall.

**Q 7 4 Marks Networking Questions**

1. (i) Production Unit and Media Unit- MAN  
Production Unit and Finance Unit- LAN  
(ii) Switch/Hub  
(iii) Optical Fibre  
(iv) Suggested layout:

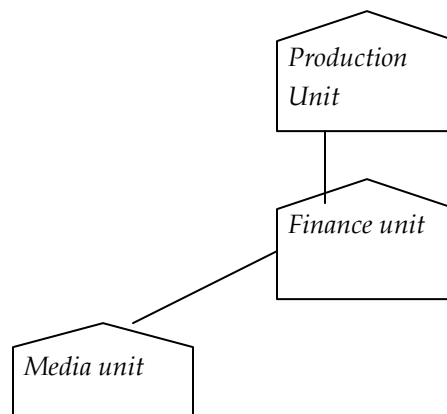

---

To connect to Delhi office – **Satellite**

2. (i) Back Office and Work Office -LAN  
Back Office and South Office – WAN  
(ii) Switch / Hub

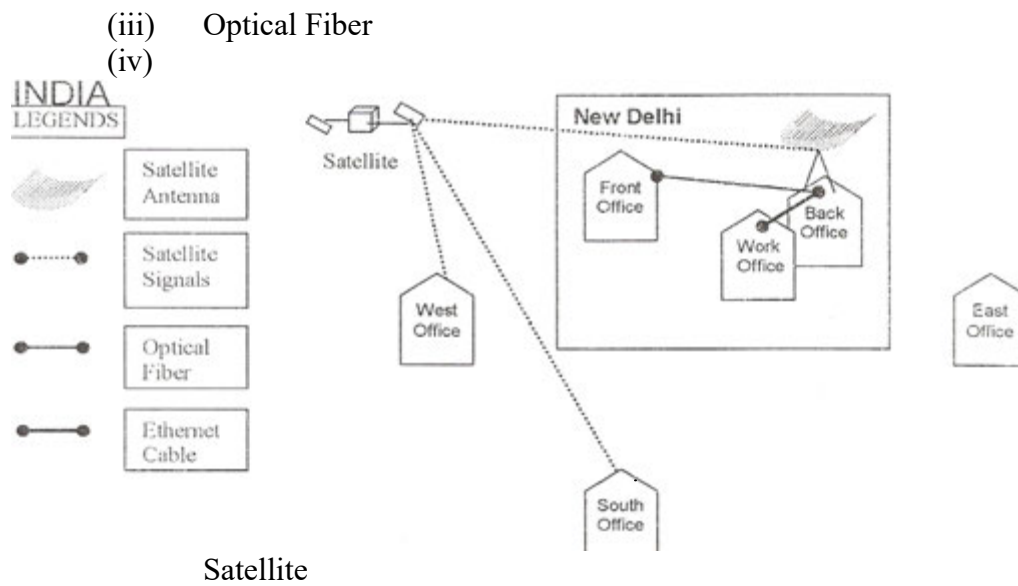

3. (i) Layout 1:

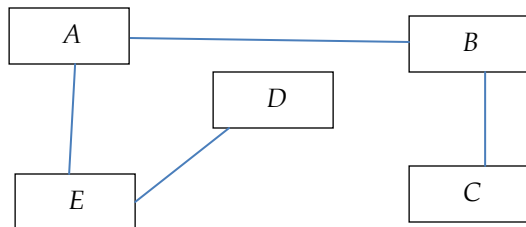

Layout 2:

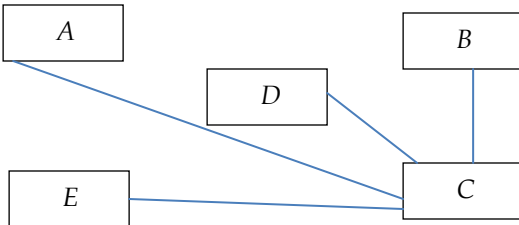

(ii) C Building

Because it has the most number of computers and as per 80-20 rule the maximum traffic should be in the network and only 20 percent traffic should go out of the network.

(iii) Repeater : between building A and C, between building E and C

Switch : In each building

Modem : In building C

(iv) Optical Fibre is the best possible wired communication link.

4. (i) Head Office and Tech Office: LAN

Head Office and Coimbatore Office: **WAN**

- (ii) Switch/Hub
  - (iii) Optical fiber
  - (iv) Optical Fiber/Star Topology  
Satelite communication
- OR
- Optical Fiber/Bus Topology
  - Satelite communication

