

MATHEMATICS

The syllabus in the subject of Mathematics has undergone changes from time to time in accordance with growth of the subject and emerging needs of the society.

The curriculum at Secondary stage primarily aims at enhancing the capacity of students to employ Mathematics in solving day to day life problems and studying the subjects as a separate discipline. It is expected that students should acquire the ability to solve problems using algebraic methods and apply the knowledge of simple trigonometry to solve problem of heights and distances, Carrying out experiments with numbers and forms of geometry, framing hypothesis and verifying these with further observations from inherent part of Mathematics learning at this stage. The proposed curriculum includes the study of number system, algebra, geometry, trigonometry, mensuration, statistics, graphs and coordinate geometry etc.

The teaching of Mathematics should be imparted through activities which may involve the use of concrete materials, models, patterns, charts, pictures, posters, games, puzzles and experiments.

COURSE STRUCTURE**CLASS – X****SUMMATIVE – I**

FIRST TERM		MARKS: 90
UNITS		MARKS
(i)	NUMBER SYSTEMS Real Numbers	11
(ii)	ALGEBRA Polynomials, Pair of linear Equations in two Variables	23
(iii)	GEOMETRY Triangles	17
(v)	TRIGONOMETRY Introduction to Trigonometry, Trigonometric Identity	22
(vii)	STATISTICS	17
TOTAL		90

CLASS – X**SUMMATIVE – II**

SECOND TERM		MARKS: 90
UNITS		MARKS
(ii)	ALGEBRA (contd.) Quadratic equations, Arithmetic progressions	23
(iii)	GEOMETRY (contd.) Circles, Constructions.	17
(iv)	MENSURATION Area Related to Circles, Surface Areas & Volumes	23
(v)	TRIGONOMETRY (contd.) Height & Distances	08
(vi)	COORDINATE GEOMETRY	11
(vii)	PROBABILITY	08
TOTAL		90

COURSE STRUCTURE

Chapter – 1 : Real Numbers

Contents

1. Euclid’s division lemma
2. Fundamental Th^m of arithmetic
3. Proof of results
 - (a) Irrationality of
 - (i) $\sqrt{2}$
 - (ii) $\sqrt{3}$
 - (iii) $\sqrt{5}$
4. Decimal expansions of rational numbers in terms of terminating / non terminating recurring decimals.

Learning Objective

1. To acquire the knowledge of Euclid’s theories.
2. To recollect the previous knowledge through Euclid’s division algorithm.
3. To understand irrationality of numbers.
4. To understand fundamental theorem of Arithmetic.

Key Term

1. Irrational numbers
2. Division Algorithm
3. Lemma
4. Terminating / non terminating decimals

~~~~~  
**Chapter – 2 : Polynomials**

**Contents**

1. Zeroes of polynomial
2. Relationship between zeroes and coefficients of polynomial with particular reference to quadratic polynomials.
3. Statements & simple problems on division algorithm.

**Learning Objective**

1. To recollect the knowledge about zeros of polynomials.
2. To relate zeroes and coefficient of a polynomial with reference to quadratic, polynomials.
3. To apply division algorithm on polynomials.

**Key Term**

1. Zero of a polynomial
2. Degree of an Eq<sup>n</sup>
3. Coefficient
4. Division Algorithm for polynomials

**Chapter – 3 : Pair of Linear Equations in Two Variables****Contents**

1. Pair of linear Eq<sup>n</sup> in two variables.
2. Geometric representation of different possibilities of solutions / inconsistency.
3. Algebraic conditions for number of solutions.
4. Solution of pair of linear Eq<sup>n</sup> in two variables by
  - (a) Substitution Method
  - (b) Elimination Method
  - (c) Cross Multiplication
5. Situational problems.
6. Simple problems on equations reducible to linear eq<sup>n</sup>.

**Learning Objective**

The students should be able to learn the following

1. The graph of linear eq<sup>n</sup> is a straight line.
2. The graph of an eq<sup>n</sup> of the type  $x = k$  is a line parallel to the y axis at a distance k units from y axis.
3. The graph of an eq<sup>n</sup> of the type  $y = k$  is a line parallel to x axis at a distance of k units from the x axis.
4. Any system of eq<sup>n</sup>s which has atleast one solution is called consistent.

**Key Term**

1. Consistent System
2. Inconsistent System
3. Unique / Infinitely many / No solution
4. Equations reducible to linear eq<sup>n</sup>s.

**Chapter – 4 : Quadratic Equations****Contents**

1. Standard form of a quad. Eq<sup>n</sup>  $ax^2 + bx + c = 0$  ( $a \neq 0$ )
2. Solution of the quadratic equations only real roots by
  - (a) Factorisation
  - (b) Completing the square
  - (c) Quadratic formula
3. Relationship between discriminant and nature of roots.
4. Problems related to day to day activities.

**Learning Objective**

To learn the following facts

1. A second degree eq<sup>n</sup>s of the form  $ax^2 + bx + c = 0$  where a, b, c are real numbers and  $a \neq 0$  are called quadratic eq<sup>n</sup>.
2. If  $ax^2 + bx + c = 0$  equivalent to  $(x - a)(x - b) = 0$  then  $x = a$  and  $x = b$  is a solution.
3. If  $ax^2 + bx + c = 0$  has a & b as roots of eq<sup>n</sup> then sum of roots =  $-b/a$ . Product of roots =  $c/a$ .
4.  $(b^2 - 4ac)$  is called the discriminant of the eq<sup>n</sup> and
  - if  $D > 0 \Rightarrow$  Real & Distinct Roots
  - if  $D = 0 \Rightarrow$  Real & Equal Roots
  - if  $D < 0 \Rightarrow$  No Real Roots

**Key Term**

1. Roots of an eq<sup>n</sup>.
2. Discriminant
3. Real & Non Real Roots
4. Quadratic Formula  $\Rightarrow x = \frac{-b \pm \sqrt{b^2 - 4ac}}{2a}$

**Chapter – 5 : Arithmetic Progressions****Contents**

1. Definition of progression.
2. What is Arithmetic Progression?
3. Derivation of n<sup>th</sup> term.
4. Derivation of sum of first n terms.

**Learning Objective**

After studying this the students will be able to define :

1. Arithmetic progression which is obtained if there exists a constant number such that
  - $a_2 = a_1 + d$
  - $a_3 = a_2 + d$
  - 
  - 
  - and so on
2. A particular sequence is an AP or not by checking  $a_2 - a_1 = a_3 - a_2$ .

**Key Term**

1. Arithmetic Progression
2. Sum to n terms
3. n<sup>th</sup> term
4. Condition of A.P

**Chapter – 6 : Triangles****Contents**

1. Def's, examples of similar  $\Delta$ s.
2. (Prove) If a line is drawn parallel to one side of a triangle to intersect the other two sides in distinct points, the other two sides are divided in the same ratio.
3. (Prove) If a line divides two sides of a triangle in the same ratio, the line is parallel to the third side.
4. (Motivate) If in two triangles corresponding angles are equal, their corresponding sides are proportional and the triangles are similar.
5. (Motivate) If the corresponding sides of two triangles are proportional, their corresponding angles are equal and the two triangles are similar.
6. (Motivate) If one angle of a triangle is equal to one angle of another triangle and the sides including these angles are proportional, the two triangles are similar.
7. (Motivate) If a perpendicular is drawn from the vertex of the right angle of a triangle on each side of the perpendicular, the two triangles so formed are similar to the whole triangle and to each other.
8. (Prove) The ratio of the areas of two similar triangles is equal to the ratio of the square of their corresponding sides.
9. (Prove) In a right triangle, the square of the hypotenuse is equal to the sum of the squares of the other two sides.
10. (Prove) In a triangle, if the square of one side is equal to the sum of the squares of the other two sides, the angle opposite to the first side is a right angle.

**Learning Objective**

1. To acquire the knowledge about the new concept 'similarity'.
2. To clarify the difference between similarity and congruency.
3. To apply the theorems based on different situations.
4. To make students aware about new concepts.

**Key Term**

1. Similarity
2. Perpendicularity

**Chapter – 7 : Coordinate Geometry****Contents**

1. Review the concepts of coordinate geometry done earlier.
2. Awareness of geometric representations of quadratic polynomials.
3. Distance between two points.
4. Section formula (Internal Division)
5. Area of triangle and condition of collinearity.

**Learning Objective**

1. To acquire the knowledge about coordinate system.
2. To acquire the knowledge to find distance using coordinates.

**Key Term**

- Distance formula =  $A(x_1, y_1), B(x_2, y_2)$   
 $AB = \sqrt{(x_2 - x_1)^2 + (y_2 - y_1)^2}$
- Section formula =  $(\frac{m_1x_2 + m_2x_1}{m_1 + m_2}, \frac{m_1y_2 + m_2y_1}{m_1 + m_2})$   
Where  $m_1 : m_2 =$  Internal division Ratio  
 $(x_1, y_1)$  &  $(x_2, y_2)$  – coordinates
- Mid point formula =  $(\frac{x_1 + x_2}{2}, \frac{y_1 + y_2}{2})$
- Area of  $\Delta$  =  $\frac{1}{2} |x_1(y_2 - y_3) + x_2(y_3 - y_1) + x_3(y_1 - y_2)|$
- Condition of collinearity =  $x_1(y_2 - y_3) + x_2(y_3 - y_1) + x_3(y_1 - y_2) = 0$

**Chapter – 8 (A) : Trigonometric Ratios****Contents**

- Trigonometric ratios of an acute angle of a right angled triangle.
- Values of angles from  $0^\circ$  to  $90^\circ$  (with proofs)
- Relationships between the ratios.

**Learning Objective**

- To acquire the knowledge of all trigonometric ratios of all the angles.
- To motivate the ratios.

**Key Term**

- Trigonometric ratios

$$(a) \text{ Sine} = \frac{P}{H} \quad (b) \text{ Cosine} = \frac{B}{H} \quad (c) \text{ Tangent} = \frac{P}{B}$$

$$(d) \text{ Cosecant} = \frac{H}{P} \quad (e) \text{ Secant} = \frac{H}{B} \quad (f) \text{ Cotangent} = \frac{B}{P}$$

Where P = Perpendicular, B = Base, H = Hypotenuse

- Relationships between trigonometric ratios as

$$(a) \text{ cosec } A \cdot \sin A = 1$$

$$(b) \text{ sec } A \cdot \cos A = 1$$

$$(c) \text{ cot } A \cdot \tan A = 1$$

$$(d) \frac{\sin A}{\cos A} = \tan A$$

$$(e) \text{ cot } A = \frac{\cos A}{\sin A}$$

**Chapter – 8 (B) : Trigonometric Identities****Contents**

1. Proof and application of the identity.
2. Simple identities
3. Trigonometric ratios of complementary angles.

**Learning Objective**

To help the students to apply the identities according to the situations

1. Trigonometric Identities
  - (a)  $\sin^2 \theta + \cos^2 \theta = 1$
  - (b)  $1 + \tan^2 \theta = \sec^2 \theta$
  - (c)  $1 + \cot^2 \theta = \operatorname{cosec}^2 \theta$
2. Complementary Angle
  - (a)  $\sin (90 - \theta) = \cos \theta$
  - (b)  $\cos (90 - \theta) = \sin \theta$
  - (c)  $\tan (90 - \theta) = \cot \theta$
  - (d)  $\cot (90 - \theta) = \tan \theta$
  - (e)  $\sec (90 - \theta) = \operatorname{cosec} \theta$
  - (f)  $\operatorname{cosec} (90 - \theta) = \sec \theta$

**Chapter – 9 : Height And Distances****Contents**

1. Problems on heights and distances.
2. Angles of elevation / depression should be only  $30^\circ$ ,  $45^\circ$ ,  $60^\circ$ .
3. Problems involving maximum to two right triangles.

**Learning Objective**

1. To acquire the knowledge of line of sight, angle of elevation & depression.
2. To use angles in finding out the height or distance of building.

**Key Term**

1. Angle of elevation
2. Angle of Depression

**Chapter – 10 : Circles****Contents**

1. Def<sup>n</sup> of tangents
2. Difference between tangent and chord.
3. The tangent at any point of a circle is perpendicular to the radius through the point of contact (Prove).

4. The length of tangents drawn from an external point to a circle are equal. (Prove)

**Learning Objective**

1. To acquire the knowledge of tangency.
2. To clarify the difference between a chord and a tangent.

**Key Term**

1. Tangent
2. Secant
3. Chord

~~~~~  
Chapter – 11 : Constructions

Contents

1. Division of a line segment in a given ratio (Internally)
2. Tangents to a circle from a point outside it.
3. Construction of a triangle similar to given triangle.

Learning Objective

1. To make students able to construct the figures based on given conditions.

Key Term

1. Internal division
2. External division

~~~~~  
**Chapter – 12 : Areas Related to The Circles.**

**Contents**

1. Areas of circle, sectors and segments of circle.
2. Problems based on areas and perimeter / circumference of the above said plane figure (In calculating area of segment of a circle, problem should be restricted to central angle of  $60^\circ$ ,  $90^\circ$  &  $120^\circ$  only. Plane figures involving triangle simple quadrilaterals and circles should be taken)

**Learning Objective**

1. To acquire the knowledge about sectors and segments.
2. To study about the area of plane figures.

**Key Term**

1. Sector of a circle
  2. Segment of a circle
  3. Length of arc
  4. Central angle
- ~~~~~

**Chapter – 13 : Surface Areas And Volumes**

**Contents**

1. Problems on finding surface areas and volumes of combinations of any two of the following :- cubes, cuboid, spheres, hemispheres and right circular cylinders, cones. Frustum of a cone
2. Problems involving converting one type of metallic solid into another and other mixed problems. (Problems with combination of not more than two different solids be taken.)

**Learning Objective**

1. To acquire the knowledge to find out the volume & surface area.
2. To make students able to find the areas of the figures in combination.

**Key Term**

1. Surface area
2. Volume
3. Frustum of cone

~~~~~  
Chapter – 14 : Statistics

Contents

1. Mean, Median
2. Mode of Grouped Data (Bimodal situation to be avoided.)
3. Cumulative frequency graph.

Learning Objective

1. To motivate the students about mean, median and mode.
2. To acquire the knowledge about the study of graph.

Key Term

1. Mean
 2. Median
 3. Mode
 4. Cumulative frequency graph
- ~~~~~

Chapter – 15 : Probability

Contents

1. Defⁿ of probability
2. Connection with probability as given in class IX.
3. Simple problems on single events, not using set notation.

Learning Objective

1. To study about probability

Key Term

1. Probability
2. Event
3. Sample space

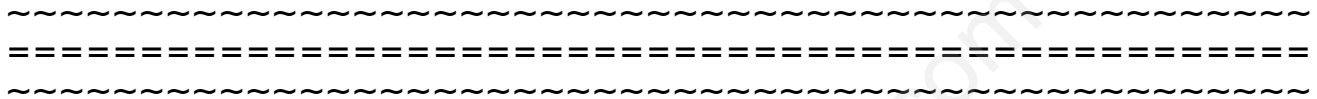

www.studiestoday.com

ASSIGNMENTS**Chapter (1) : Real Numbers**

- Q.1. By Euclid division Algorithm find the H.C.F. of**
 (i) 44 and 128 (ii) 4052 and 12576
- Q.2. Using fundamental theorem of Arithmetic, find the H.C.F. and L.C.M. of :-**
 (i) 570 and 1425 (ii) 30, 72 and 432
- Q.3. Using fundamental th^m of arithmetic. Find prime factorizations of :-**
 (i) 884 (ii) 2400
- Q.4. By applying the fundamental th^m of arithmetic, find the HCF of 8624 and 21658. By using $HCF \times LCM = \text{product of two numbers}$, find LCM of the above numbers.**
- Q.5. Prove that the square of any positive integer is of the form $5q$, $5q+1$, $5q+4$ for any integer q .**
- Q.6. Show that $5 + \sqrt{3}$ is irrational.**
- Q.7. Show that the sum and product of two irrational numbers $5 + \sqrt{3}$ and $5 - \sqrt{3}$ are rational numbers.**
- Q.8. If the H.C.F. of 408 and 1032 is expressible in the form $1032x - 408 \times 5$, find the value of x .**
- Q.9. Classify as rational and irrational numbers :**
- | | |
|-----------------------|---------------------------------|
| (i) $\sqrt{7}$ | (v) 0.73457456 _____ |
| (ii) $\sqrt{4}$ | (vi) Reciprocal of $\sqrt{361}$ |
| (iii) $\frac{\pi}{2}$ | (vii) $0.\overline{66}$ |
| (iv) 5.7 | (viii) $\sqrt[3]{5}$ |
- Q.10. Without long division state whether the following expressions are terminating or non-terminating decimals :-**
- | | | |
|----------------------|--|------------------------|
| (i) $\frac{201}{25}$ | (ii) $\frac{243}{5^2 \times 2^3 \times 7^2}$ | (iii) $\frac{9}{27}$ |
| (iv) $\frac{1}{8}$ | (v) $\frac{59}{4}$ | (vi) $\frac{5000}{70}$ |

Chapter (2) : Polynomials

Q.1. Show :-

(i) $px^2 + (2q - p^2)x - 2pq$ have p & $-\frac{2q}{p}$ as zero

(ii) $x = -2\frac{2}{3}$ is a zero of $(3x + 8)(2x + 5)$

Q.2. Find the value of K for which the given value is a zero of the given quadratic polynomial :-

(i) $x^2 - (a + b)x + K$, $x = b$

(ii) $x^2 - (\sqrt{3} + 1)x + \sqrt{3}$, $x = \sqrt{3}$

Q.3. The graphs of polynomials $y = p(x)$ for some polynomials are given. Classify these as linear or quadratic or cubic. Also state the number of zeroes :-

(i)

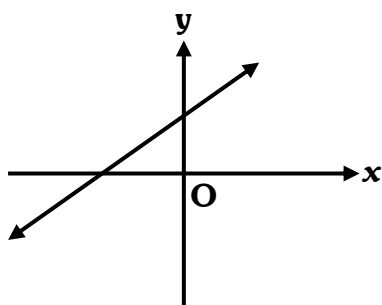

(ii)

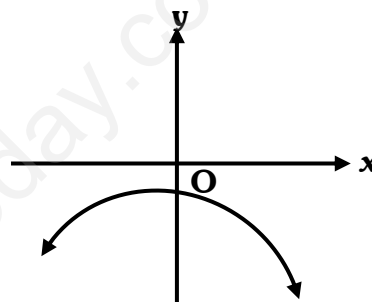

(iii)

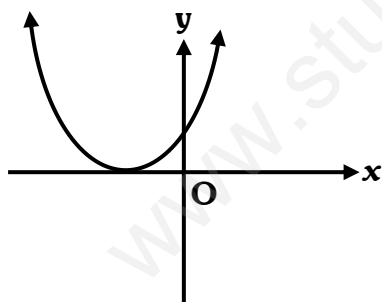

(iv)

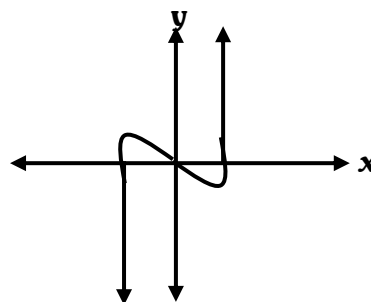
Q.4. Find the zeroes of the following polynomial and verify the relation between zeroes of a polynomial and its coefficients $x^2 + 4x - 192$.Q.5. If α and β are the zeros of Quadratic polynomial $f(x) = kx^2 + 4x + 4$ s.t. $\alpha^2 + \beta^2 = 24$. Find the values of k .Q.6. If α and β are zeros of $P(x) = x^2 - 2\sqrt{2}x + 6$, find the quadratic polynomial $q(x)$ whose zeroes are $\frac{1}{\alpha}$ and $\frac{1}{\beta}$.Q.7. What must be subtracted from or added to $8x^4 + 14x^3 - 2x^2 + 8x - 12$ so that it may be exactly divisible by $4x^2 + 3x - 2$?Q.8. Find whether or not $x^2 + 5x + 4$ is a factor of $x^4 + 5x^3 + 3x^2 - x + 4$?

- Q.9. Find the value of a when $ax^3 + 3x^2 - 3$ and $3x^3 - 5x + a$ leave the remainder R_1 and R_2 when divided by $x - 4$ and $R_1 + R_2 = 0$.
- Q.10. Divide the polynomial $f(x) = 3x^2 - x^3 - 3x + 5$ by the polynomial $g(x) = x - 1 - x^2$ and verify the division algorithm.

=====

Chapter (3) : Linear Eqⁿs in Two Variables

- Q.1. Solve the following equations graphically $3x + y - 11 = 0$ & $x - y = 1$. Find the area of Δ so formed between these lines and y axis.
- Q.2. Solve for x & y
- $$\frac{a}{x} - \frac{b}{y} = 0$$
- $$\frac{ab^2}{x} + \frac{a^2b}{y} = a^2 + b^2, \text{ where } x, y \neq 0$$
- Q.3. For what values of p & q does the following pair of equations have an infinite number of solutions?
- $$2x + 3y = 7$$
- $$(p + q)x + (2p - q)y = 21$$
- Q.4. 4 men and 6 boys can finish a piece of work in 20 days while 3 men and 4 boys can finish it in 28 days. Find the time taken by one man and one boy alone to finish the work.
- Q.5. The students of a class are made to stand in rows. If no. of students of each row is reduced by 2, the number of rows increases by 1 but if the number of students in each row is increased by 3 the number of rows is reduced by 1. Find the number of students in a class.
- Q.6. A train covered a certain distance at a uniform speed. If the train would have been 6 km/h faster, it would have taken 4 hours less than the scheduled time. And, if the train were slower by 6 km/h, it would have taken 6 hrs more than the scheduled time. Find the length of the journey.
- Q.7. Two years ago, a father was five times as old as his son. Two years later, his age will be 8 more than 3 times the age of the son. Find the present ages of father and son.
- Q.8. A two digit number is 4 more than 6 times the sum of its digits. If 18 is subtracted from the number, the digit are reversed. Find the number.

Chapter (4) : Quadratic Equations**Q.1. Using quadratic formula, solve for x :**

(i) $(x^2 - 5x)^2 - 7(x^2 - 5x) + 6 = 0$

(ii) $a^2b^2x^2 - (4b^4 - 3a^4)x - 12a^2b^2 = 0$

Q.2. Find the roots by factorization method

(i) $6\left(\frac{x-4}{x-1}\right)^2 + 13\left(\frac{x-4}{x-1}\right) = 5$

(ii) $\frac{a}{ax-1} + \frac{b}{bx-1} + a + b = 0$

(iii) $x^2 + \left(\frac{a}{a+b} + \frac{a+b}{a}\right)x + 1 = 0$

(iv) $\frac{1}{a+b+x} = \frac{1}{a} + \frac{1}{b} + \frac{1}{x}$

Q.3. If the equation $(1 + m^2)x^2 + 2mcx + (c^2 - a^2) = 0$ has equal roots. Prove that $c^2 = a^2(1 + m^2)$ **Q.4. Find K for which**

(i) $(4 - K)x^2 + (2K + 4)x + (8K + 1) = 0$ (Perfect Square)

(ii) $(p - q)^2x^2 + 2(p^2 - q^2)x + k = 0$ (Equal Roots)

Q.5. Out of a group, $\frac{7}{2}$ times the square root of the number are playing on the shore of a pond, the two remaining ones are swinging in water. Find the total number of swans.**Q.6. The sum of two numbers is 23. The sum of their reciprocals is $\frac{23}{120}$. Find the numbers.****Q.7. A farmer wishes to start a 100 m^2 rectangular vegetable garden since he has only 30 m barded wire, he fences the three sides of the rectangular garden letting his house compound wall as the fourth side. Find the dimensions of the garden.****Q.8. A two digit number is seven times the sum of its digits and is also equal to 12 less than three times the product of its digits. Find the number.**

=====

Chapter (5) : Arithmetic Progressions

- Q.1. Let a sequence be defined by $a_1=1$, $a_2=1$ and $a_n=a_{n-1}+a_{n-2}$ for all $n>2$. Find $\frac{a_{n+1}}{a_n}$ for $n=2$.
- Q.2. If 5 times the 5th term of an A.P. is equal to 7 times the 7th term, then prove that the 12th term is zero.
- Q.3. Which term of the sequence $20, 19\frac{1}{4}, 18\frac{1}{2}, 17\frac{3}{4} \dots$ is the first negative term?
- Q.4. If sum to first n terms of an A.P. is $3n^2 - 2n$, find the A.P.
- Q.5. How many terms of the A.P. $-6, -\frac{11}{2}, -5, \dots$ are needed to give the sum -25 . Explain the double answer.
- Q.6. The sum of 5th and 9th terms of an A.P. is 72 and the sum of 7th and 12th term is 97. Find the A.P.
- Q.7. Find the sum of all three digit no's which leave remainder 1, when divided by 4.
- Q.8. Determine K if $4K + 8$, $2K^2 + 3K + 6$ and $3K^2 + 4K + 4$ are the consecutive terms of A.P.

=====
Chapter (6) : Triangles

- Q.1. If $AB \parallel CD$, Find x

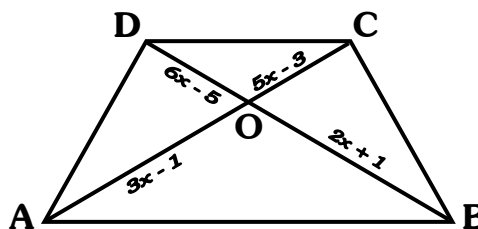

- Q.2. PA, QB and RC are \perp to AC and $AP = x$, $QB = z$, $RC = y$, $AB = a$ & $BC = b$.
Prove that $\frac{1}{x} + \frac{1}{y} = \frac{1}{z}$

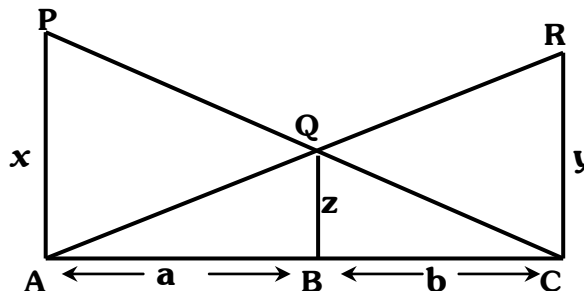

- Q.3. $\angle A = \angle CED$, Prove that $\triangle CAB \sim \triangle CED$. Also find x.

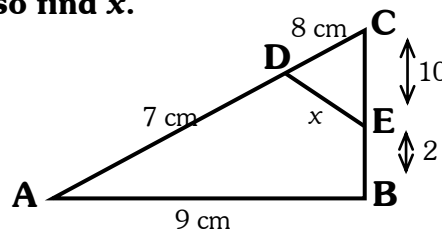

Q.4. Find the ar (ΔPQR)

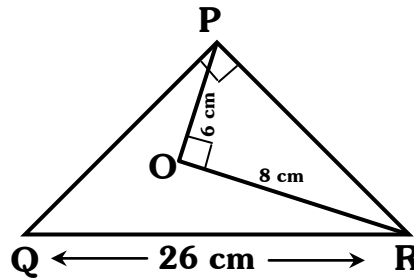

- Q.5. The perimeters of two similar triangles are 25cm & 15cm respectively. If one side of 1st Δ is 9cm, what is the corresponding side of the other Δ .
- Q.6. A vertical pillar AB is bent at c at a height of 24 m and its upper end B touches the ground at a distance of 1.8 m from the end A on the ground. Find the height of the pillar.
- Q.7. ΔABC is an isosceles right angled Δ . Similar Δ s ΔABE and ΔACD are constructed on sides AC and AB. Find the ratio of ar (ΔABE) and ar (ΔACD).
- Q.8. In trapezium ABCD, O is the point of intersection of AC and BD and $AB \parallel CD$ and $AB = 2CD$. If ar (ΔAOB) = 84 cm², find ar (ΔCOD)

=====

Chapter (7) : Coordinate Geometry

- Q.1. Find the coordinate of the point equidistant from three given points A(5,3), B(5,-5) & C(1,-5)
- Q.2. Find the ratio in which the line $x - y - 2 = 0$ divides the line segment joining the Points (3, -1) and (8, 9). Also find the coordinates of this point.
- Q.3. If point (x, y) lies on the line joining (b, 0) and (0, a), show that $\frac{x}{b} + \frac{y}{a} = 1$
(use condition of collinearity)
- Q.4. If A (- 3, 2), B (a, b) and C (- 1, 4) are vertices of an isosceles triangle. Show that $a + b = 1$ if $AB = BC$.
- Q.5. If A (x, y), B (1, 2) and C (2, 1) are the vertices of a Δ of area 6 square units, show that $x + y = 15$ or -9 .
- Q.6. If A (-4, 6), B (2, -2) and C (2, 5) are the vertices of a Δ .ABC. Find the length of median through A and coordinates of centroid of the Δ .
- Q.7. If the vertex of a Δ is (1, 1) and the middle points of the sides through it is (-2, 3) and (5, 2), find the other vertices.
- Q.8. If the coordinates of the midpoint of the sides of a Δ are (1, 1), (2, -3) and (2,4), find the vertices of the Δ .

=====

Chapter (8) : Trigonometry

Q.1. If $\cot \theta = \frac{1}{\sqrt{3}}$, prove that $\frac{1 - \cos^2 \theta}{2 - \sin^2 \theta} = \frac{3}{5}$

Q.2. Find θ in each of the following:-

(i) $\sqrt{3} \tan 2\theta - 3 = 0$

(ii) $\tan 3\theta = \sin 45^\circ \cos 45^\circ + \sin 30^\circ$

Q.3. If $\sin(A + B) = 1$ and $\cos(A - B) = \frac{\sqrt{3}}{2}$ and $0 \leq A + B \leq 90^\circ$ and $A > B$, find A & B.

Q.4. If $\cos \theta + \sin \theta = \sqrt{2} \cos \theta$, show that $\cos \theta - \sin \theta = \sqrt{2} \sin \theta$.

Q.5. If $x \sin^3 \theta + y \cos^3 \theta = \sin \theta \cos \theta$ and $x \sin \theta = y \cos \theta$. Prove that $x^2 + y^2 = 1$

Q.6. Prove :-

(i) $\left(\frac{1}{\cos \theta} - \frac{1}{\sin \theta}\right) \left(1 + \frac{\sin \theta}{\cos \theta} + \frac{\cos \theta}{\sin \theta}\right) = \tan \theta \sec \theta - \cot \theta \operatorname{cosec} \theta$

(ii) $2(\sin^6 \theta + \cos^6 \theta) - 3(\sin^4 \theta + \cos^4 \theta) + 1 = 0$

Q.7. If $\tan \theta + \sin \theta = m$ and $\tan \theta - \sin \theta = n$, prove that $m^2 - n^2 = 4\sqrt{mn}$.

Q.8. Evaluate :-

(i) $\tan 1^\circ \cdot \tan 2^\circ \cdot \tan 3^\circ \dots \tan 89^\circ$.

(ii) $2(\cos^4 60^\circ + \sin^4 30^\circ) - (\tan^2 60^\circ + \cot^2 45^\circ) + 3 \sec^2 30^\circ$.

Chapter (9) : Application of Trigonometry

Q.1. The angle of elevation of a cloud from a point 60m above a lake is 30° and the angle of depression of the reflection of cloud is 60° . Find the height of the cloud.

Q.2. The angle of elevation of a jet plane from a point A on the ground is 60° . After a flight of 30 seconds, the angle of elevation changes to 30° . If the jet plane is flying at a constant height of $3600\sqrt{3}$ m, find the speed of the jet plane.

Q.3. An aeroplane at an altitude of 200 meters observes the angles of depression of opposite points on the two banks of a river to be 45° and 60° . Find the width of the river.

- Q.4. The angle of elevation of the top Q of a vertical tower PQ from a point X on the ground is 60° . At a point Y, 40m vertically above X, the angle of elevation is 45° . Find the height of the tower PQ.
- Q.5. An aeroplane at an altitude of 1200 metres finds that two ships are sailing towards it in the same direction. The angles of depression of the ships as observed from the aeroplane are 60° and 30° respectively. Find the distance between the two ships.
- Q.6. A fire in a building B is reported on telephone to two fire stations E and F, 10 km apart from each other on a straight road. E observes that the fire is at an angle of 60° to the road and F observes that it is at an angle of 45° to the road. Which station should send its team and how much will this team have to travel?
- Q.7. A parachutist is descending vertically. At a certain height his angle of elevation from a point on the ground is 60° and after his descending 600 m vertical distance further, angle of elevation becomes 45° from the same point of observation. Find the height of ground from the place where the parachutist descends.
- Q.8. The shadow of a flagstaff is three times as long as the shadow of the flagstaff when the sun rays meet the ground at an angle of 60° . Find the angle between sun rays and the ground at the time of longer shadow.

=====

Chapter (10) : Circle

- Q.1. ABCD is a quadrilateral such that $\angle D = 90^\circ$. A circle C (O, r) touches the sides AB, BC, CD and DA at P, Q, R and S respectively if $BC = 38$ cm, $CD = 25$ cm and $BP = 27$ cm. Find r.

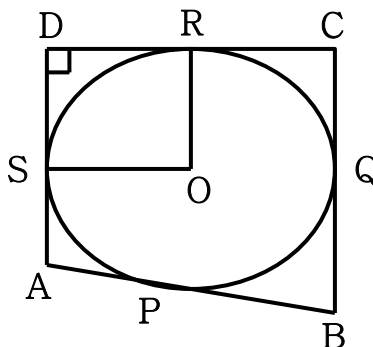

- Q.2. A circle is touching side BC of ΔABC at P and is touching AB & AC when produced at Q & R.
Prove that $AQ = \frac{1}{2}$ (Perimeter of ΔABC)
- Q.3. PA and AQ are two tangents drawn from an external points A to a circle C (O,r) such that $\angle PAQ = 120^\circ$. Prove that $AO = 2AP$.
- Q.4. O is the centre of a circle of radius 8cm. The tangent at a point A on the circle cuts a line through O at B such that $AB = 15$ cm. Find OB.

- Q.5. PA and PB are tangent from P to the circle with other O. At point M, a tangent drawn cutting PA at K and PB at N. Prove that $KN = AK + BN$.
- Q.6. Prove that the tangents at the extremities of any chord make equal angles with the chord.
- Q.7. $\triangle ABC$ is a right triangle with $\angle A = 90^\circ$ such that $AB = 6$ cm & $AC = 8$ cm. A circle with centre O is inscribed in the triangle ABC. Calculate the radius of the inscribed circle.
- Q.8. A circle is inscribed in a $\triangle ABC$ having sides $AB=8$ cm, $BC=10$ cm and $CA=12$ cm. Find AD, BF and CE.

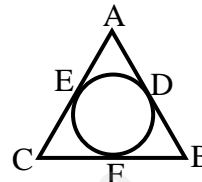

=====
Chapter (11) : Constructions

- Q.1. Draw a circle of radius 6 cm with centre O. Draw a diameter AOB. Through A or B draw a tangent to the circle.
- Q.2. Divide a line segment of length 11 cm in the ratio 2 : 5 internally.
- Q.3. Construct a tangent to a circle of radius 1.8 cm from a point on the concentric circle of radius 2.8 cm and measure its length. Also verify the measurement by actual calculation.
- Q.4. Construct a $\triangle PBC$, similar to a given isosceles $\triangle PQR$, with $QR = 2.8$ cm, $PR=PQ=2.5$ cm, with scalar factor 6:7.

=====
Chapter (12) : Areas Related to Circles

- Q.1. Three horses are tied with 7m long ropes at the three corners of a triangular field having sides 20m, 34m and 42m. Find the area of the plot which can be grazed by the horses. Also, find the area of the plot which remains ungrazed.
- Q.2. The circumference 132 cm of a circle A is equal to the sum of the circumferences of two circles B and C. The radius of the circle B is 14 cm. Find the radius of the circle C.
- Q.3. PQRS is a diameter of a circle of radius 6cm. The lengths PQ, QR and RS are equal. Semi-circles are drawn on PQ and QS as diameters as shown. Find the perimeter and area of the shaded region.

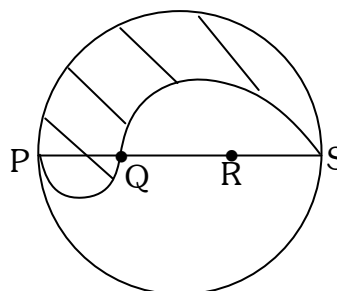

- Q.4. Prove that the area of circular path of uniform width 'h' surrounding a circular region of radius 'r' is $\pi h (h + 2r)$
- Q.5. ABC is a right angle triangle in which $\angle A = 90^\circ$, AB = 21cm and AC = 28cm. Semicircles are described on AB, BC and AC as diameters. Find the area of the shaded region.

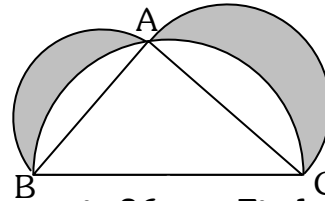

- Q.6. If the perimeter of a semicircular protractor is 36 cm. Find the diameter of the protractor.
- Q.7. The short and long hands of a clock are 4cm & 6cm long respectively. Find the sum of the distances travelled by their tips in two days.
- Q.8. A paper is in the form of a rectangle ABCD in which AB = 20cm and BC=14cm. A semi-circular portion with BC as diameter is cut off. Find the area of remaining part.

=====
Chapter (13) : Surface Areas and Volumes

- Q.1. Lead balls of diameter 6 cm are dropped into a cylindrical vessel of diameter 24 cm and height 16 cm, $\frac{3}{4}$ th filled with water. Find the no. of lead balls that should be dropped into the cylindrical vessel so that the vessel is full and no water overflows.
- Q.2. A tent is made in the form of a frustum of a cone surmounted by another cone. The diameters of the base and the top of the frustum are 20m & 6m respectively and the height is 24m. If the height of the tent is 28m and the radius of the conical part is equal to the radius of the top of the frustum, find the quantity of canvas required.
- Q.3. The dimensions of a metallic cuboid are 100cm × 8cm × 64cm. It is melted and recast into a cube. Find the total surface area of the cube.
- Q.4. A semicircular sheet of metal of diameter 28 cm is bent into an open conical cup. Find the depth and capacity of the cup.
- Q.5. A sector of a circle of radius 12cm has the angle 120° . It is rolled up so that the two bounded radii are joined to form a cone. Find the volume of the cone.
- Q.6. A cone, a hemisphere and a cylinder stand on equal bases and have the same height. Show that their volumes are in the ratio 1 : 2 : 3.
- Q.7. A solid is composed of a cylinder with hemispherical ends. If the whole length of the solid is 98 cm and the diameter of the hemispherical ends is 24 cm, find the cost of polishing the surface at the rate of 15 paise per sq.cm.
- Q.8. Find the volume of the largest right circular cone that can be cut out of a cube whose edge is 9cm.

Chapter (14) : Statistics

Q.1. Daily pocket expenses (in Rs.) of 80 students of a school are given in the table below.

Expenses (In Rs.)	No. of Students
0 – 5	5
5 – 10	15
10 – 15	20
15 – 20	10
20 – 25	10
25 – 30	15
30 – 35	5

- (i) Draw 'less than' and 'more than' ogives on the same graph.
(ii) Hence find the median of the frequency distribution.
(iii) Find median by using the formula.
(iv) Verify that median in both cases has the same value.

Q.2. Using Empirical formula, find the mode for the following :-

Class	20 – 25	25 – 30	30 – 35	35 – 40	40 – 45
Frequency	3	8	8	3	2

Q.3. Find the mode of the following distribution.

Height (In cms)	No. of Plants
0 – 20	10
20 – 40	35
40 – 60	52
60 – 80	61
80 – 100	38
100 – 120	29

Q.4. The mean of the following distribution is 25. If the sum of the frequencies is 106, find f_1 and f_2 .

X	19	21	23	25	27	29	31
F	13	15	f_1	18	16	f_2	13

Q.5. Frequency table of the marks obtained by 229 students is given below :

Marks obtained	No. of Students
10 – 20	12
20 – 30	30
30 – 40	f_1
40 – 50	65
50 – 60	f_2
60 – 70	25
70 – 80	18

Given that median marks are 46. Find the missing frequencies f_1 and f_2 .

VERY SHORT QUESTIONS**CHAPTER (1)****M.C.Q.**

Q.1. Write the sum of exponents of prime factors in prime factorization of 196.

(i) 2

(iii) 4

(ii) 7

(iv) 9

Q.2. If HCF (72, 120) = 24, then what is the LCM (72, 120)?

(i) 360

(iii) 300

(ii) 260

(iv) 200

Q.3. Decimal Expansion of $\frac{13}{120}$ is:

(i) Terminating

(iii) Non terminating

(ii) Non terminating repeating

(iv) Non terminating non repeating

Q.4. By which smallest rational number $\sqrt{27}$ should be multiplied so as get a rational number.

(i) $\sqrt{3}$ (iii) $\sqrt{27}$

(ii) 3

(iv) 9

Q.5. If $x (\neq 0)$ is a rational number and y is irrational number, then what can you say about $(x + y)$ & xy .

(i) Terminating

(iii) Non terminating

(ii) Non terminating repeating

(iv) Non terminating non repeating

One Mark Questions

Q.1. Why the number $(21)^n$, where n is a natural number, cannot end with 0?

Q.2. Define Euclid's Division lemma.

Q.3. Express 140 as a product of its prime factors.

Q.4. If $\frac{p}{q} = 43.123456$, what can you say about the prime factors of q .

Q.5. If p and q are two prime numbers, then find their HCF.

CHAPTER (2)**M.C.Q.****Q.1. Write the degree of : $2u^5 - 7u^4 - \sqrt{3}u$**

- (i) 1
(ii) 4

- (iii) 5
(iv) 10

Q.2. What is the zero of the polynomial $ax + b$, $a \neq 0$?

- (i) $-a$
(ii) $-b$

- (iii) $-a/b$
(iv) $-b/a$

Q.3. How many maximum zeros will a polynomial of degree two has?

- (i) 0
(ii) 1

- (iii) 2
(iv) 3

Q.4. What are the zeroes of: $x^2 + x - 2$

- (i) 1, 2
(ii) $-1, 2$

- (iii) $-1, -2$
(iv) 1, -2

Q.5. Graph of a Quadratic Equation is a:

- (i) Straight line
(ii) Curve

- (iii) Parabola
(iv) Circle

One Mark Questions

- Q.1. Is $x = -3$ a zero of the polynomial $2x^3 + 4x^2 - 5x + 3$?
- Q.2. Write a polynomial, whose zeroes are $\frac{1}{2}, 0$.
- Q.3. Write a polynomial whose product & sum of the zeros are $\frac{-9}{2}$ and $\frac{-3}{2}$ respectively.
- Q.4. The graphs of $y = p(x)$ are given below. Write the number of zeroes of $p(x)$ in each case.

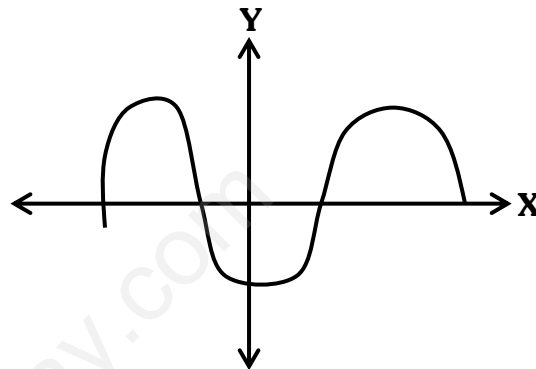
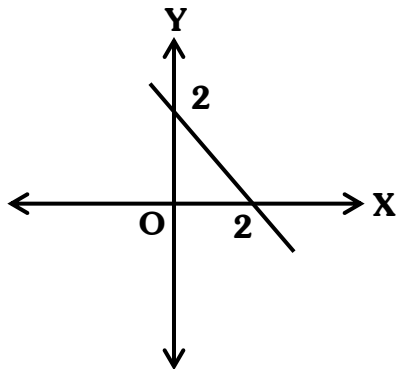

- Q.5. The graphs of $y = p(x)$ are given below. Write the zeroes of $p(x)$.

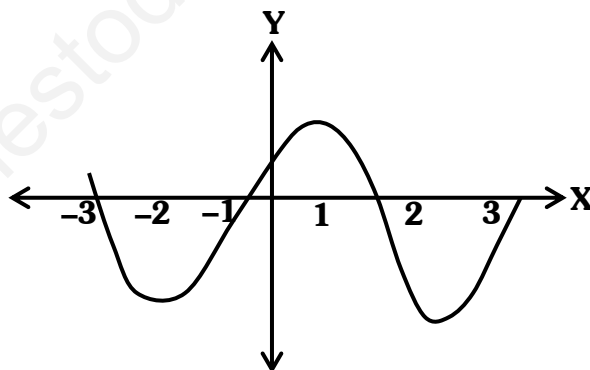
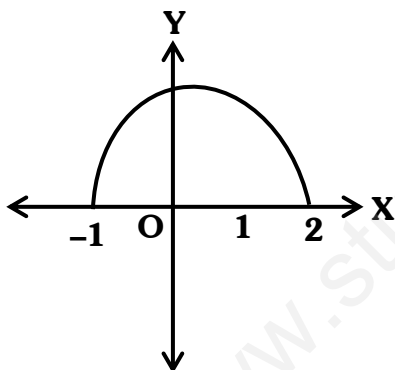

=====

CHAPTER (3)

M.C.Q.

- Q.1. For what value of m the following pair of linear equations represent parallel lines? $4x + my - 8 = 0$ and $3x - 5y + 7 = 0$

(i) $m = \frac{-20}{3}$

(iii) $m = \frac{20}{3}$

(ii) $m \neq \frac{-20}{3}$

(iv) $m \neq \frac{20}{3}$

- Q.2. For what value of K the following pair of linear equations may have a consistent solution - $2x + Ky = 7$ and $3x + 9y = 13$

(i) $k = 6$

(ii) $k \neq 6$

(iii) $k = -6$

(iv) $k \neq -6$

Q.3. On comparing the ratios $\frac{a_1}{a_2}$, $\frac{b_1}{b_2}$ & $\frac{c_1}{c_2}$, state the kind of lines represented by the following pair of linear eqⁿs. $x + 4y = 12$ and $2x - 3y = 15$

(i) Intersecting

(iii) Coincident

(ii) Parallel

(iv) None of the above

Q.4. Give the equation of a line which is parallel to the x-axis and is at a distance of 6 units above it.

(i) $y = 6$

(iii) $y = 0$

(ii) $x = 6$

(iv) $x = -6$

Q.5. The eqⁿ of a line parallel to y axis is of the form _____.

(i) $x = 0$

(iii) $x = k$

(ii) $y = 0$

(iv) $y = k$

One Mark Questions

Q.1. Write the number of solutions of the following pair of linear equations:

(i) $x + 3y - 4 = 0$

(ii) $2x + 6y = 7$

Q.2. The sum of two numbers is 24 and one number is five times the other number. Form a pair of linear eqⁿ.

Q.3. Is $x = 3$ & $y = -2$ a solution of $5x - 3y = 9$?

Q.4. How many solution do two linear equations in two variable have if their graphs Intersect at one point

Q.5. Form a pair of linear equations –

“The larger of the two supplementary angles is 40° larger than the smaller one”

CHAPTER (4)

M.C.Q.

Q.1. If $ax^2 + bx + c = 0$ has equal roots, then $c =$

(i) $-\frac{b}{2a}$

(ii) $\frac{b}{2a}$

(iii) $\frac{-b^2}{4a}$

(iv) $\frac{b^2}{4a}$

Q.2. What are the roots of $x^2 - 6x = 7$?

- (i) $-1, 7$ (iii) $1, -7$
(ii) $-1, -7$ (iv) $1, 7$

Q.3. Form a quadratic equation whose roots are -1 and 3 .

- (i) $x^2 - 2x + 3$ (iii) $x^2 + 2x + 3$
(ii) $x^2 - 2x - 3$ (iv) $x^2 + 2x - 3$

Q.4. For what value of p the following quad. Eqⁿ have real roots? $px^2 + 4x - 3 = 0$

- (i) $p = \frac{4}{3}$ (iii) $p \geq \frac{4}{3}$
(ii) $p > \frac{4}{3}$ (iv) $p \geq -\frac{4}{3}$

Q.5. For what value of K does the eqⁿ have equal roots? $3x^2 + Kx + 4 = 0$

- (i) $k = 4$ (iii) $k > 3\sqrt{4}$
(ii) $k > 4\sqrt{3}$ (iv) $k = 4\sqrt{3}$

One Mark Questions

Q.1. State whether $(x + 3)^2 = 3x(x - 2)$ is a quadratic eqⁿ or not.

Q.2. Write the quadratic equation for the following :-

Square of number is four less than five times the number.

Q.3. Find the ratio of sum and product of the roots of the equation

$$3x^2 + 12 - 13x = 0.$$

Q.4. State the condition so that the eqⁿ $ax^2 + bx + c = 0$, $a \neq 0$ may have

- (i) Equal Real Roots (iii) No Real Roots.
(ii) Two different Real Roots

Q.5. The eqⁿ $5x^2 + (9 + 4p)x + 2p^2 = 0$ & $5x + 9 = 0$ have the same zero. Find p .

CHAPTER (5)

M.C.Q.

Q.1. The 11th term of the sequence defined by $a_n = (-1)^{n-1} n^3$ is

- (i) 1220 (iii) 1331
(ii) 1221 (iv) 1330

Q.2. What is the common difference of the A.P. :-

$$a + b, (a + 1) + b, (a + 1) + (b + 1), \text{-----}$$

(i) a

(iii) b

(ii) 1

(iv) $a + b$

Q.3. If $a_{23} - a_{18} = 45$ find d .

(i) 5

(iii) 9

(ii) 45

(iv) 18

Q.4. What is the sum of the first 10 even natural numbers?

(i) 100

(iii) 120

(ii) 110

(iv) 90

Q.5. For what value of K the numbers, x , $2x + K$ & $3x + 6$ are three consecutive terms of an A.P.?

(i) 1

(iii) 3

(ii) 2

(iv) 4

One Mark Questions

Q.1. If n^{th} term of an A.P. is $(2n + 1)$, find the sum of first n terms of the A.P.

Q.2. Find the 8th term from the end of the A.P. 7, 10, 13, _____, 184

Q.3. If the common difference of an AP is 5, then find $a_{15} - a_{11}$.

Q.4. Find the missing term:-

$$0, \text{---}, -8, -12, \text{---}$$

Q.5. Which term of the A.P. 1, -1, -3, -5, _____ is -57?

CHAPTER (6 & 7)

Q.1. If $\cos \theta = \frac{p}{q}$. Evaluate $\frac{1}{p} \sec \theta$.

(i) $\frac{1}{p}$

(iii) $\frac{q}{p^2}$

(ii) $\frac{1}{q}$

(iv) $\frac{p}{q^2}$

Q.2. If $\sin A = \sqrt{3} \cos A$ and A is an acute angle. Find $\angle A$.

(i) 30°

(iii) 60°

(ii) 45°

(iv) 90°

Q.3. If $\sin \theta + \cos \theta = 1$ then find the value of $\sin \theta \cdot \cos \theta$.

- (i) 0 (iii) $\sin \theta$
(ii) 1 (iv) 2

Q.4. From the adjoining fig, find BC.

- (i) $3\sqrt{2}$ (iv) $\frac{\sqrt{3}}{2}$
(ii) $2\sqrt{3}$
(iii) $\frac{-2}{\sqrt{3}}$

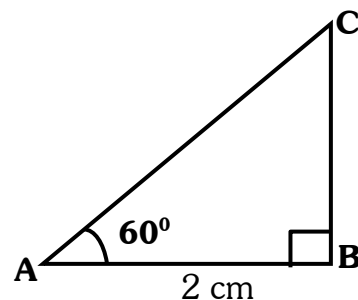

Q.5. If $\sec \theta + \tan \theta = x$ then the value of $\sec \theta - \tan \theta$ in terms of x is

- (i) x^2 (iii) $x/2$
(ii) $1/x$ (iv) x^3

One Mark Questions

Q.1. From the adjoining fig, find the values of $\tan P - \cot R$.

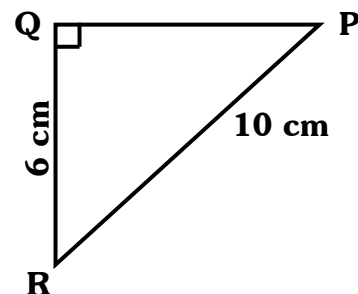

Q.2. If $\sin A = \frac{5}{7}$. Calculate $\tan A$.

Q.3. If $\operatorname{cosec} \theta = \sqrt{5}$. Find the value of $\cot \theta - \tan \theta$.

Q.4. If $\cos A = \frac{2}{5}$ & $A + B = 90^\circ$. Find the value of $\sin B$.

Q.5. Evaluate $\tan 19^\circ \tan 37^\circ \tan 71^\circ \tan 53^\circ$.

Q.6. If a pole 6m high casts a shadow $2\sqrt{3}$ m long on the ground then find the sun's elevation.

Q.7. A kite is flying at a height of $40\sqrt{3}$ m from the level ground, attached to a string inclined at 60° to the horizontal. What is the length of the string?

Q.8. If $\operatorname{cosec} \theta = 2$, $\cot \theta = \sqrt{3}p$, find p .

Q.9. If $\tan A = \frac{5}{6}$. Find $1 - \cot A$.

Q.10. If $\sin 3\theta = \cos 4\theta$ then find the value of 7θ

CHAPTER (8)

M.C.Q.

Q.1. In the adjoining fig, OABC is a rectangle with OA = 5 units and OC = 3 units. What are the coordinates of the point B?

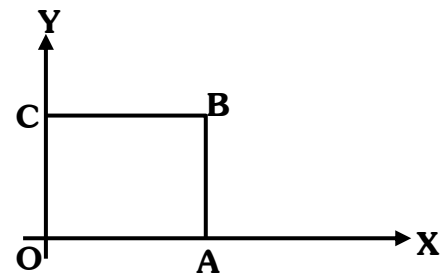

- (i) (5, 3)
- (ii) (3, 5)
- (iii) (0, 5)
- (iv) (3, 0)

Q.2. What is the distance of the point (3, -4) from the origin?

- (i) 3 units
- (ii) 4 units
- (iii) 5 units
- (iv) 12 units

Q.3. What is the distance of the point (-4, -2) from the x axis?

- (i) 2 units
- (ii) 4 units
- (iii) $\sqrt{20}$ units
- (iv) 8 units

Q.4. From the adjoining fig, find the area of the ΔABC .

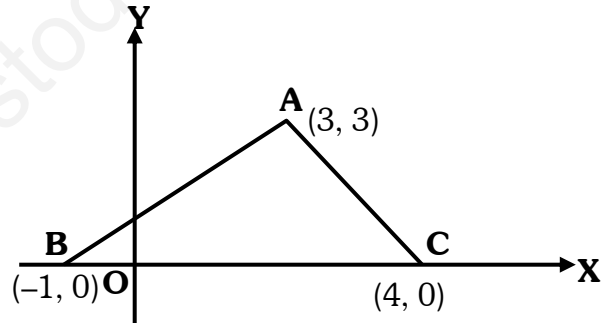

- (i) 6 sq. units
- (ii) 7 sq. units
- (iii) 7.5 sq. units
- (iv) 15 sq. units

Q.5. What can you say about the coordinates of any point of x axis?

- (i) (x, a)
- (ii) (x, 0)
- (iii) (0, a)
- (iv) (0, y)

One Mark Questions

Q.1. In the adjoining fig, OAB is an equilateral triangle with side 4 units. What are the coordinates of vertex B?

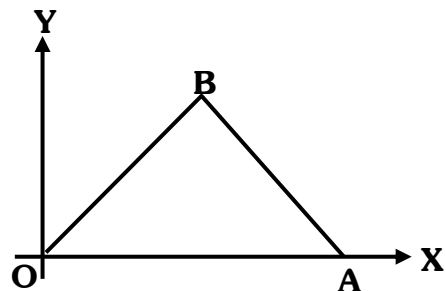

One Mark Questions

Q.1. Check whether $\triangle ABC \sim \triangle PQR$

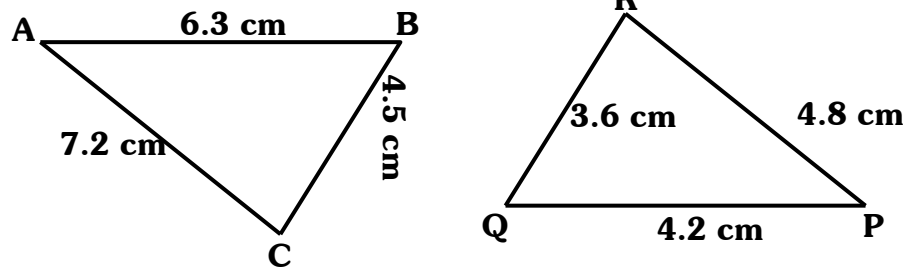

- Q.2. Find the length of the hypotenuse of an isosceles right \triangle whose one side is $4\sqrt{2}$ cm.
- Q.3. ABC and BDE are two equilateral \triangle s such that D is the midpoint of BC, then the ratio of areas of \triangle s ABC and BDE is _____.
- Q.4. If $\triangle ABC \sim \triangle PQR$ such that $PQ = 3$ cm, $QR = 2$ cm, $RP = 2.5$ cm and $BC = 4$ cm, find the perimeter of $\triangle ABC$.
- Q.5. In $\triangle ABC$, $AB = 6\sqrt{3}$ cm, $AC = 12$ cm & $BC = 6$ cm. What is the measure of $\angle B$.

=====

CHAPTER (10)

M.C.Q.

Q.1. In the adjoining fig, PA and PB are tangents from P to a circle with centre C. If the radius of the circle is 4 cm and $PA \perp PB$, then find the length of each tangent.

- (i) 2 cm
- (ii) 3 cm
- (iii) 4 cm
- (iv) 8 cm

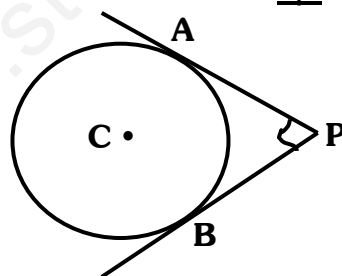

Q.2. A square circumscribes a circle of radius 5 cm. Find the length of diagonal of the square.

- (i) $5\sqrt{2}$ cm
- (ii) 5 cm
- (iii) 10 cm
- (iv) $10\sqrt{2}$ cm

Q.3. Find PQ and PR. If $OP = 13$ cm, $OQ = 5$ cm

- (i) 4 cm
- (ii) 8 cm
- (iii) 6 cm
- (iv) 12 cm

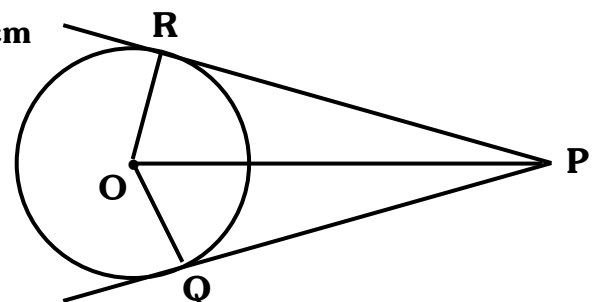

Q.4. A quad. PQRS is circumscribed touching the circle at A, B, C & D. If AP = 5 cm, QR = 7 cm and CR = 3 cm, then find the length of PQ.

- (i) 8 cm
- (ii) 9 cm

- (iii) 7 cm
- (iv) 11 cm

Q.5. What is the length of tangent drawn from a point whose distance from the centre of a circle is 20 cm and radius of circle is 16 cm?

- (i) 26 cm
- (ii) 24 cm

- (iii) 12 cm
- (iv) 15 cm

One Mark Question

Q.1. Find the distance between two parallel tangents of a circle of radius 3cm.

Q.2. If two tangents inclined at 60° are drawn to a circle of radius 3cm, then find the length of each tangent.

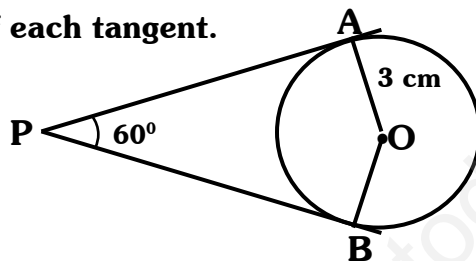

Q.3. If PT is a tangent of the circle with centre O and $\angle TPO = 25^\circ$, then find x.

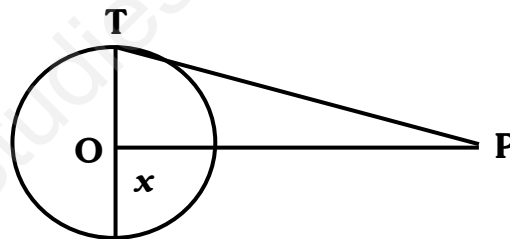

Q.4. In the given figure if QP = 4.5cm, then find QR.

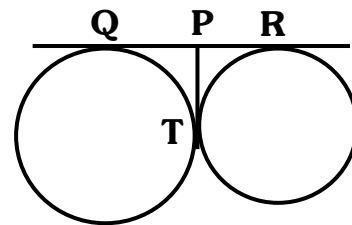

Q.5. Find $\angle RPQ$

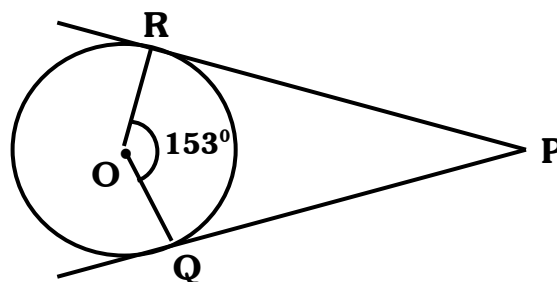

CHAPTER (12)

M.C.Q

Q.1. The length of a minute hand of a wall clock is 7 cm. What is the area swept by it in 30 min?

- (i) $\frac{77}{2} \text{ cm}^2$ (iii) 77 cm^2
 (ii) 154 cm^2 (iv) 72 cm^2

Q.2. What is the perimeter of a sector of circle of radius r cm and of central angle θ ?

- (i) $\frac{\pi r \theta}{180}$ (iii) $\frac{\pi r \theta}{360}$
 (ii) $\frac{\pi r^2 \theta}{180}$ (iv) $\frac{\pi r^2 \theta}{360}$

Q.3. What is the radius of the circle whose circumference and area are numerically equal?

- (i) 1 unit (iii) 3 units
 (ii) 2 units (iv) 4 units

Q.4. Find the perimeter of the quadrant if radius of the circle of which the quadrant is a part is 7 cm.

- (i) 11 cm
 (ii) 18 cm
 (iii) 25 cm
 (iv) 14 cm

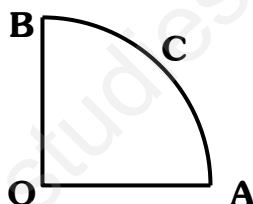

Q.5. The area of a square is same as the area of a circle. What is the ratio of their perimeters?

- (i) $2 : \sqrt{\pi}$ (iii) $2 : \pi$
 (ii) $1 : 2\sqrt{\pi}$ (iv) $2 : \sqrt{2}$

One Mark Questions

**Q.1. What is the area of shaded region?
 OA = 10. cm, OB = 14 cm**

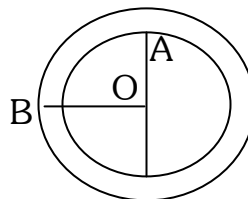

Q.2. What is the perimeter of semicircular protractor whose diameter is 14 cm?

Q.3. In a circle of radius 14 cm, an arc subtends an angle of 60° at the centre. Find the length of the arc.

- Q.4. The sum of the circumferences of two circles is 110 cm. If the diameter of one of them is 28 cm, what is the diameter of the other circle?
- Q.5. Three horses are tied to each corner of a triangular field with a rope of 7 cm. Find the total area of the field that these horses can graze.

CHAPTER (13)**M.C.Q.**

- Q.1. What is the surface area of a cube whose volume is 64 cm^3 ?
- (i) 4 cm^2 (iii) 96 cm^2
(ii) 24 cm^2 (iv) 32 cm^2
- Q.2. A wooden solid sphere of radius $r \text{ cm}$ is divided into two equal parts. What is the whole surface area of the two parts?
- (i) πr^2 (iii) $3\pi r^2$
(ii) $2\pi r^2$ (iv) $4\pi r^2$
- Q.3. The base radii of a cone and a cylinder are equal. If their volumes are also equal, then find the ratio of their heights?
- (i) $3 : 1$ (iii) $2 : 3$
(ii) $1 : 3$ (iv) $3 : 2$
- Q.4. A cylinder, a cone and a hemisphere are of equal bases and have the same height. What is the ratio of their volumes?
- (i) $3 : 1 : 2$ (iii) $2 : 3 : 1$
(ii) $1 : 2 : 3$ (iv) $2 : 1 : 3$
- Q.5. What is the ratio of the areas of a circle and an equilateral triangle whose diameter and a side are respectively equal?
- (i) $2\pi : \sqrt{3}$ (iii) $\pi : 2\sqrt{3}$
(ii) $\pi : \sqrt{3}$ (iv) $3\pi : 2$

One Mark Questions

- Q.1. In the adjoining fig, the bottom of the glass has a hemispherical raised portion. The glass is filled with juice. How much juice a person will get?

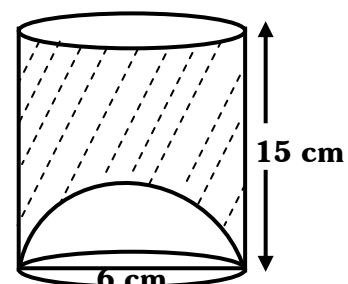

One Mark Questions

Q.1.

Class	30 – 35	35 – 40	40 – 45	45 – 50	50 – 55	55 – 60	60 – 65
Frequency	14	16	18	23	18	8	3

For the given distribution find the difference of the upper limit of the median class and lower limit of the modal class.

Q.2. The mean of first 8 observations is 12.5 and the mean of next 7 observations is 5. What is the mean of all the observations?

Q.3. Find Mean, Median, Mode of :-
3, 7, 5, 8, 5, 3, 1, 4

Q.4. Write the class marks of classes 10 – 25 and 35 – 55.

Q.5. If 89 is added to the data given below, what is the increase in the median?
45,49,52,53,67,77,81,99.

=====

CHAPTER (15)

M.C.Q.

Q.1. Find the probability of getting a vowel in English alphabets.

(i) $\frac{21}{26}$ (iii) $\frac{5}{21}$ (ii) $\frac{5}{26}$ (iv) $\frac{26}{21}$

Q.2. How many possible outcomes will be there when a coin is tossed thrice?

(i) 4

(iii) 8

(ii) 2

(iv) 16

Q.3. A dice is rolled. What is the probability of getting no. divisibly by 5?

(i) 0

(iii) $\frac{5}{6}$ (ii) $\frac{1}{6}$

(iv) 1

Q.4. If the probability of winning a game is $\frac{4}{9}$, what is the probability of losing it?

(i) $\frac{2}{9}$ (iii) $\frac{4}{9}$ (ii) $\frac{3}{9}$ (iv) $\frac{5}{9}$

Q.5. A dice is thrown once. What is the probability of getting a prime number?

(i) $\frac{1}{6}$ (iii) $\frac{5}{6}$ (ii) $\frac{2}{6}$ (iv) $\frac{1}{2}$

~~~~~

**One Mark Questions**

- Q.1. Two dice are tossed simultaneously. Find the probability of getting a sum less than 13.
- Q.2. A number is selected at random from the numbers 9, 9, 9, 9, 7, 7, 7, 7, 5, 5, 3. Find the probability that the selected number is their average.
- Q.3. A bag contains 5 red balls and  $n$  green balls. If the probability of drawing a green balls is three times that of a red ball, then find the value of  $n$ .
- Q.4. Cards with numbers 2 to 101 are placed in a box. If a card is selected at random. Find the probability that the card has a square number.
- Q.5. A number 'x' is selected from numbers  $-2, -1, 0, 1, 2$ . What is the probability that  $x^2 < 1$ ?

=====

**Value Based Questions**

- Q.1 Ravi a social worker has a bucket in the shape of a frustum of cone having area of bases  $40\text{cm}^2$  and  $160\text{cm}^2$  with the height 45cm. Ravi decided to serve tea to the people living in orphanage. He fills the bucket with tea, then serve it in small cylindrical glasses each having diameter of base 4cm and height 7cm.
- Find volume of the bucket. ( $\pi=22/7$ )
  - Find number of glasses needed by him.
  - Which moral value of Ravi is depicted here?
- Q.2 In a town, school is located at S and temple is located at T. Coordinates of S and T being  $(-3, 3)$  and  $(9, 3)$  respectively. Two brothers Ram and Shyam live in a house situated at  $(1, -3)$ . Both study in same school. Ram always gets ready early and first goes to temple to worship and then from temple goes to school but Shyam directly goes to school from his house.
- Find the distance covered by Ram daily to reach school.
  - Find the distance covered by Shyam daily to reach school.
  - Which concept will you use to find above distances?
  - Which moral values can be learnt from Ram?
- Q.3 There are 45 students in a class in which 25 are girls and 20 are boys. The class teacher has to select one student for the class representative. She writes the name of each student on separate card, put them into bag and stir thoroughly. She then draws one card from the bag. What is the probability that the name written on the card is of a
- Girl
  - Boy
  - Which moral values of a class teacher is depicted here?
- Q.4 A contractor plans to install two slides for the children to play in a park. For the children below the age of 5 years he prefers to have a slide whose top is at a height of 1.5m and it is inclined at an angle of  $30^\circ$  to the ground, whereas for older children he wants to have a steep at a height 3m and inclined at an angle of  $60^\circ$  to the ground.

- (i) What should be the length of the slide in each case?
- (ii) Which moral value is hidden in this problem?

Q.5 In a school, students thought of planting trees in and around the school to reduce air pollution. It was decided that the number of trees that each section of each class will plant, will be the same as the class in which they are studying. For example, a section of class I will plant one tree, a section of class II will plant two trees and so on till class XII. There are three section of each class.

- (i) How many trees in all will be planted by the students?
- (ii) Which mathematical concept is used in above problem?
- (iii) Which moral values can be learnt from above problem?

=====

~~~~~

=====

www.studiestoday.com

MODEL TEST PAPER (SOLVED)
SUMMATIVE ASSESSMENT – I**(CLASS – X)****Time: 3hrs.****M.M.:90****General Instructions:**

- (i) All questions are **compulsory**.
- (ii) The question paper consists of **34** questions divided into four **sections A, B, C and D**. **Section-A** comprises of **8** questions of **1 mark** each; **Section-B** comprises of **6** questions of **2 marks** each; **Section-C** comprises of **10** questions of **3 marks** each and **Section-D** comprises of **10** questions of **4 marks** each.
- (iii) Question numbers **1 to 8** in **Section-A** are multiple choice questions where you are required to select one correct option out of the given four.
- (iv) There is no overall choice. However, internal choices have been provided in **1** question of **two marks**, **3** questions of **three marks** each and **2** questions of **four marks** each. You have to attempt only one of the alternatives in all such questions.
- (v) Use of calculator is not permitted.

SECTION: 'A'

- Q.1 Which of the following numbers has non-terminating repeating decimal expansion ?
(A) $\frac{13}{80}$ (B) $\frac{17}{160}$ (C) $\frac{93}{420}$ (D) $\frac{63}{240}$
- Q.2 If $\sqrt{\frac{5}{3}}$ and $-\sqrt{\frac{5}{3}}$ are the zeroes of a polynomial $p(x)$, then $p(x)$ is
(A) $25x^2 - 9$ (B) $3x^2 - 5$ (C) $x^2 - 25$ (D) $9x^2 - 25$
- Q.3 Given that $\triangle ABC \sim \triangle DEF$. If $\text{ar}(\triangle ABC) = 121 \text{ cm}^2$, $\text{ar}(\triangle DEF) = 196 \text{ cm}^2$ and $AC = 13.2 \text{ cm}$ then the length of DF is :
(A) 16.8 cm (B) 8.8 cm (C) 15.4 cm (D) 12 cm
- Q.4 If $\sin 2A = 2\sin A$ is true, then A equals :
(A) 0° (B) 30° (C) 45° (D) 60°
- Q.5 The number $\frac{\sqrt{5}+3}{\sqrt{5}-3}$ is :
(A) a rational number (B) an irrational number
(C) an integer (D) a natural number
- Q.6 Two lines are given to be parallel. The equation of one of the lines is $4x + 3y = 14$. The equation of the second line can be :
(A) $3x + 4y = 14$ (B) $8x + 6y = 28$
(C) $12x + 9y = 42$ (D) $-12x = 9y$
- Q.7 If $\sec 2A = \text{cosec}(A - 27^\circ)$ where $2A$ is an acute angle, then the measure of $\angle A$ is :
(A) 35° (B) 37° (C) 39° (D) 21°
- Q.8 If the mean of a distribution is 30, and the median is 35, then the mode of that distribution is :
(A) 30 (B) 35 (C) 45 (D) 15

SECTION – B

- Q.9 Express 2431 as a product of its prime factors.
- Q.10 Find the sum and product of the zeroes of the polynomial $p(x) = 5x^2 + 14x - 3$.
- Q.11 In the given figure, $DE \parallel BC$. If $\frac{AD}{AB} = \frac{3}{5}$, $AE = 7.5$ cm, then find EC.

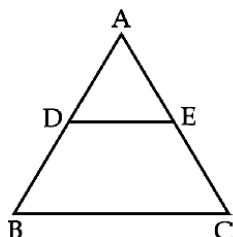

- Q.12 If $\cos(A + B) = 0$ and $\sin(A - B) = \frac{1}{2}$, then find the value of A and B where A and B are acute angles.
- Q.13 Find the polynomial whose zeroes are $3 + \sqrt{5}$ and $3 - \sqrt{5}$.
- Q.14 Change the distribution to less than type distribution :

Class	50 - 55	55 - 60	60 - 65	65 - 70	70 - 75	75 - 80
Frequency	2	8	12	24	38	16

OR

Calculate the mode of the following distribution :

Classes	10 - 15	15 - 20	20 - 25	25 - 30	30 - 35
Frequency	4	7	20	8	1

SECTION – C

- Q.15 If AD and PM are altitudes of $\triangle ABC$ and $\triangle PQR$ respectively where $\triangle ABC \sim \triangle PQR$, then prove that $\frac{AB}{PQ} = \frac{AD}{PM}$.
- Q.16 If α and β are zeroes of the polynomial $3x^2 - 2x - 8$, then find the polynomial whose zeroes are $\frac{1}{\alpha}$ and $\frac{1}{\beta}$.
- Q.17 Use Euclid's division lemma to show that the square of any positive integer is of the form $3m$ or $3m + 1$ for some integer m .

OR

Find the HCF and LCM of the numbers 513 and 437 and verify $\text{HCF} \times \text{LCM} = \text{product of the two numbers}$.

- Q.18 Without using trigonometric tables evaluate :

$$\frac{\sec^2 54^\circ - \cot^2 36^\circ}{\cos^2 57^\circ - \tan^2 33^\circ} + 2\sin^2 38^\circ \sec^2 52^\circ - \sin^2 45^\circ$$

- Q.19 Divide the polynomial $(x^3 - 3x^2 - 12x + 19)$ by $(x^2 + x - 6)$ and verify the result by division algorithm.

Q.20 Solve the following pair of equations for x and y :

$$2x - \frac{6}{y} = 1, \quad 3x + \frac{2}{y} = 7$$

Also find k such that $y = kx - 6$

OR

Solve for x and y :

$$39x + 43y = 203 ; 43x + 39y = 207$$

Q.21 Consider the following distribution of daily wages of 50 workers of a factory :

Daily wages (in Rs.)	100 - 120	120 - 140	140 - 160	160 - 180	180 - 200
Number of workers	12	14	8	6	10

Find the mean daily wage of a worker.

Q.22 Prove that the sum of the squares of the sides of a rhombus is equal to the sum of the squares of its diagonals.

OR

In an equilateral triangle, prove that three times the square of one side is equal to four times the square of one of its altitudes.

Q.23 Prove that : $\frac{\sin \theta - 2\sin^3 \theta}{2\cos^3 \theta - \cos \theta} = \tan \theta$

Q.24 The mean of the following distribution is 27. Find the value of p.

Classes	0 - 10	10 - 20	20 - 30	30 - 40	40 - 50
Frequency	8	p	12	13	10

SECTION - D

Q.25 Prove that $\sqrt{3}$ is an irrational number. Hence show that $2 + \sqrt{3}$ is also irrational.

Q.26 Solve the following pair of equations graphically $x - y + 1 = 0$; $3x + 2y - 12 = 0$ Also find the area of the triangle formed by these lines represented by the above equations and x-axis.

Q.27 Prove that : $\frac{\tan \theta}{1 - \cot \theta} + \frac{\cot \theta}{1 - \tan \theta} = 1 + \cot \theta + \tan \theta$.

Q.28 Find the median of the following data :

Value	Frequency
Less than 10	4
Less than 20	16
Less than 30	40
Less than 40	76
Less than 50	96
Less than 60	112
Less than 70	120
Less than 80	125

Q.29 Find the other zeroes of the polynomial $p(x) = 6x^4 + x^3 - 27x^2 - 2x + 30$ if two of its zeroes are $\sqrt{2}$ and $-\sqrt{2}$.

OR

If the numerator of a certain fraction is increased by 2 and denominator by 1, the fraction becomes equal to $\frac{5}{8}$. If the numerator and denominator is each diminished by 1, the fraction becomes equal to $\frac{1}{2}$, find the fraction.

Q.30 Prove that if a line is drawn parallel to one side of a triangle to intersect the other two sides in distinct points then the other two sides are divided in the same ratio.

OR

Prove that in a triangle, if square of one side is equal to the sum of the squares of the other two sides, then the angle opposite the first side is a right angle.

Q.31 If θ is an acute angle and $\tan \theta = \frac{8}{15}$

(i) evaluate : $\sec \theta + \operatorname{cosec} \theta$

(ii) verify the identity: $1 + \cot^2 \theta = \operatorname{cosec}^2 \theta$

Q.32 Sides AB and BC and median AD of a ΔABC are respectively proportional to sides PQ, QR and median PM of another ΔPQR . Show that $\Delta ABC \sim \Delta PQR$.

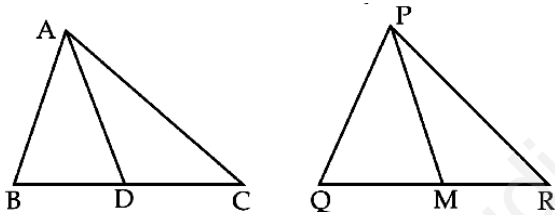

Q.33 Prove that : $\sqrt{\frac{\sec \theta - 1}{\sec \theta + 1}} + \sqrt{\frac{\sec \theta + 1}{\sec \theta - 1}} = 2 \operatorname{cosec} \theta$

Q.34 The distribution below gives the weights of 30 students of a class :

Weight (kg)	40 - 45	45 - 50	50 - 55	55 - 60	60 - 65	65 - 70	70 - 75
Number of students	2	3	8	6	6	3	2

Change the above distribution to 'more than type' distribution and draw its ogive.

SOLUTION**SECTION: 'A'**

- Q.1 C
Q.2 B
Q.3 A
Q.4 A
Q.5 B
Q.6 D
Q.7 C
Q.8 C

SECTION: 'B'

Q.9 $2431 = 11 \times 13 \times 17$

Q.10 $sum = \boxed{-14/5}$ Product = $\boxed{-3/5}$

Q.11 $DE \parallel BC \therefore \frac{AB}{DB} = \frac{3}{2} = \frac{7.5}{EC} \Rightarrow \boxed{EC = 5cm}$

Q.12 $A + B = 90$

$$\underline{A - B = 30}$$

$$2A = 120$$

$$\therefore \boxed{A = 60^\circ} \therefore \boxed{B = 30^\circ}$$

Q.13 $(x - 3 - \sqrt{5})(x - 3 + \sqrt{5})$

$$= \left[(x - 3)^2 - (\sqrt{5})^2 \right]$$

$$\therefore \text{Polynomial is } \boxed{x^2 - 6x + 4}$$

Q.14

Less than	55	60	65	70	75	80
cf	2	10	22	46	84	100

OR

$$\begin{aligned} \text{Mode} &= 20 + \frac{20 - 7}{40 - 7 - 8} \times 5 \\ &= 20 + \frac{13}{25} \times 5 = 20 + 2.6 = \boxed{22.6} \end{aligned}$$

SECTION: 'C'

Q.15 In $\triangle ABD$ and $\triangle PQM$

$$\angle B = \angle Q \text{ (} \triangle ABC \sim \triangle PQR \text{)}$$

$$\angle ADB = \angle PMQ \text{ (each } 90^\circ \text{)}$$

$\therefore \triangle ABD \sim \triangle PQM$ by AA similarity

$$\Rightarrow \frac{AB}{PQ} = \frac{AD}{PM} \quad \underline{\text{H.P.}}$$

Q.16 $\alpha + \beta = \frac{2}{3}$ $\alpha\beta = -\frac{8}{3}$

$$\frac{-b}{a} = \frac{1}{\alpha} + \frac{1}{\beta} = \frac{\beta + \alpha}{\alpha\beta} = \frac{\frac{2}{3}}{-\frac{8}{3}} = \frac{-1}{4} \times \frac{2}{2}$$

$$\frac{c}{a} = \frac{1}{\alpha\beta} = \frac{1}{-\frac{8}{3}} = \frac{3}{-8} = \frac{-3}{8}$$

$\therefore a = 8, b = 2c = -3$

ie. Polynomial = $\boxed{8x^2 + 2x - 3}$

Q.17 Let a be any positive integer and $b = 3$

Then by $a = bq + r$, $r = 0, 1, 2$

$a = 3q \Rightarrow a^2 = 9q^2 = 3(3q^2) = 3m$

$a = 3q+1 \Rightarrow a^2 = 9q^2+1+6q = 3(3q^2+2q)+1 = 3m+1$

$a = 3q+2 \Rightarrow a^2 = 9q^2+12q+3+1 = 3(3q^2+4q+1)+1 = 3m+1$

OR

$513 = 3 \times 3 \times 3 \times 3 \times 19$

HCF = 19

$437 = 19 \times 23$

LCM = $3 \times 3 \times 3 \times 3 \times 19 \times 23$

= 11799

$513 \times 437 = 224181$

$11799 \times 19 = 224181$ Hence verified

Q.18 $\frac{\sec^2 54 - \tan^2 54}{\cos^2 33 - \cot^2 33} + 2 \cos^2 52 \sec^2 52 - \frac{1}{2}$

= $\frac{1}{1} + 2 - \frac{1}{2} \Rightarrow 3 - \frac{1}{2} = \boxed{\frac{5}{2}}$ Ans

Q.19 $x^2 + x - 6 \overline{) x^3 - 3x^2 - 12x + 19} (x - 4$

$\underline{-x^3 + x^2 - 6x}$

$\underline{-4x^2 - 6x + 19}$

$\underline{+4x^2 - 4x + 24}$

$-2x - 5$

$q(x) \times g(x) + r(x) = (x^2 + x - 6)(x - 4) + (-2x - 5)$
 $= x^3 + 4x^2 + x^2 - 4x - 6x + 24 - 2x - 5$
 $= x^3 - 3x^2 - 12x + 19 = p(x)$

H.P.

Q.20 Let $\frac{1}{y} = a$

$2x - 6a = 1 \Rightarrow 2x - 6a = 1$

$3x + 2a = 7 \times 3 \quad \begin{array}{r} +9x + 6a = 21 \\ +11x \quad = +22 \end{array}$

$\therefore 3 = 6a \quad \boxed{x = 2}$

or $a = \frac{1}{2} \quad \boxed{y = 2}$

Now, $2 = 2k - 6 \Rightarrow \boxed{k = 4}$

Q.25 Let $\sqrt{3}$ be rational

$$\therefore \sqrt{3} = \frac{a}{b}, (a \text{ \& } b \text{ co-prime})$$

$$\sqrt{3}b = a$$

$$\text{or } 3b^2 = a^2$$

$\Rightarrow 3$ divides a^2 and a

$$\text{Let } a = 3c$$

$$a^2 = 9c^2$$

$$3b^2 = 9c^2$$

$$b^2 = 3c^2$$

$\Rightarrow 3$ divides b^2 & b

i.e. 3 is a common factor of a & b . Hence it is a contradiction

\therefore Our supposition is wrong

Hence $\sqrt{3}$ is irrational ----- (1)

$$\therefore \text{ For } 2 + \sqrt{3} = \frac{p}{q}$$

$$\sqrt{3} = \frac{p}{q} - 2$$

$\frac{p}{q} - 2$ is rational $\Rightarrow \sqrt{3}$ is Rational.

But $\sqrt{3}$ is irrational (from (i))

$\therefore 2 + \sqrt{3}$ is irrational.

Q.26 $y - x = 1$

x	2	0	1
y	3	0	2

$$3x - 2y = 1$$

x	2	0	1
y	3	0	2

$$\text{ar } (ABC) = \frac{1}{2} \times 5 \times 3 = 7.5 \text{ sq. units}$$

Q.27
$$\frac{\tan \theta}{1 - \frac{1}{\tan \theta}} + \frac{1/\tan \theta}{1 - \tan \theta} = \frac{\tan^2 \theta}{\tan \theta - 1} + \frac{1}{\tan \theta(1 - \tan \theta)}$$

$$\frac{\tan^3 \theta - 1}{\tan \theta(\tan \theta - 1)} = \frac{(\tan \theta - 1)(\tan^2 \theta + 1 + \tan \theta)}{\tan \theta(\tan \theta - 1)}$$

$$= \tan \theta + \cot \theta + 1 = R.H.S$$

Q.28

C.I	0-10	10-20	20-30	30-40	40-50	50-60	60-70	70-80	$\frac{n}{2} = \frac{125}{2}$
F	4	12	24	36	20	16	8	5	$\frac{125}{2}$
CF	4	16	40	76	96	112	120	125	$= 62.5$

Median class = 30 - 40

$$\text{Median} = 30 + \frac{62.5 - 40}{36} \times 10$$

$$= 30 + \frac{225}{36} = 30 + 6.25 = \boxed{36.25}$$

Q.29 $(x - \sqrt{2})(x + \sqrt{2})$ is a factor of $p(x)$

$$x^2 - 2 \Big| 6x^4 + x^3 - 27x^2 - 2x + 30 \Big| (6x^2 + x - 15)$$

$$\begin{array}{r|l} -6x^4 & \pm 12x^2 \\ \hline & x^3 - 15x^2 - 2x + 30 \\ & \underline{x^3 \quad -2x} & \left. \begin{array}{l} 6x^2 + x - 15 \\ 6x^2 + 10x - 9x - 15 \\ 2x(3x+5) - 3(3x+5) \\ (2x-3)(3x+5) \end{array} \right\} \\ \hline & -15x^2 \quad +30 \\ & \underline{-15x^2 \quad +30} \end{array}$$

i.e other zeroes are $\boxed{\frac{3}{2}, -\frac{5}{2}}$ Ans.

OR

ATQ: $\frac{x+2}{y+1} = \frac{5}{8} \Rightarrow 8x+16 = 5y+5$
 $or, 8x - 5y = -11 \quad \text{----- (i)}$

$\frac{x-1}{y-1} = \frac{1}{2} \Rightarrow 2x-2 = y-1$
 $or, 2x - y = 1 \times 5$

$8x - 5y = -11 \quad x = 8$

We have, $\frac{-10x \mp 5y = -5}{-2x} = -16 \quad y = 15 \therefore \boxed{\text{Fraction} = \frac{8}{15}}$

Q.30 Theorem: Thales or converse of Pythagoras

Q.31 $\tan \theta = \frac{8}{15} \Rightarrow P = 8k \quad B = 15k \quad H = 17k$

$\sec \theta + \operatorname{cosec} \theta = \frac{17k}{12k} + \frac{17k}{8k} = \frac{136 + 255}{120} = \frac{391}{120}$

$1 + \cot^2 \theta = 1 + \frac{225}{64} = \frac{64 + 225}{64} = \frac{289}{64}$

$\operatorname{cosec}^2 \theta = \left(\frac{17}{8}\right)^2 = \frac{289}{64}$ H.V.

Q.32 $\frac{AB}{PQ} = \frac{BC}{QR} = \frac{AD}{PM}$ (given) or $\frac{AB}{PQ} = \frac{1/2 BC}{1/2 QR} = \frac{BD}{QM}$

In $\triangle ABD$ & $\triangle PQM$

$\frac{AB}{PQ} = \frac{BD}{QM} = \frac{AD}{PM} \therefore \triangle \sim$ by sss $\Rightarrow \angle B = \angle Q$ (cpct)

Now in $\triangle ABC$ & $\triangle PQR$

$\frac{AB}{PQ} = \frac{BC}{QR}$ (given)

$\angle B = \angle Q$ (Proved) $\therefore \triangle ABC \sim \triangle PQR$ by SAS

DELHI PUBLIC SCHOOL
Indrapuram, Ghaziabad

Assignment Booklet
(Class - X : MATHS)

$$\begin{aligned} \text{Q.33} \quad & \sqrt{\frac{\sec \theta - 1}{\sec \theta + 1} \times \frac{\sec \theta - 1}{\sec \theta - 1}} + \sqrt{\frac{\sec \theta + 1}{\sec \theta - 1} \times \frac{\sec \theta + 1}{\sec \theta + 1}} \\ &= \frac{\sec \theta - 1}{\tan \theta} + \frac{\sec \theta + 1}{\tan \theta} = \frac{2 \sec \theta}{\tan \theta} = \frac{2}{\cos \theta} \times \frac{\cos \theta}{\sin \theta} \\ &= 2 \operatorname{cosec} \theta = R.H.S. \end{aligned}$$

Hence proved

Q.34

More Than	40	45	50	55	60	65	70
F	2	3	8	6	6	3	2
CF	30	28	25	17	11	5	2

Hence draw the ogive.

MODEL TEST PAPER (UNSOLVED)
SUMMATIVE ASSESSMENT – I**(CLASS – X)****Time: 3hrs****M.M.:90****General Instructions:**

- (i) All questions are **compulsory**.
- (ii) The question paper consists of **34** questions divided into four **sections A, B, C and D**. **Section-A** comprises of **8** questions of **1 mark** each; **Section-B** comprises of **6** questions of **2 marks** each; **Section-C** comprises of **10** questions of **3 marks** each and **Section-D** comprises of **10** questions of **4 marks** each.
- (iii) Question numbers **1 to 8** in **Section-A** are multiple choice questions where you are required to select one correct option out of the given four.
- (iv) There is no overall choice. However, internal choices have been provided in **1** question of **two marks**, **3** questions of **three marks** each and **2** questions of **four marks** each. You have to attempt only one of the alternatives in all such questions.
- (v) Use of calculator is not permitted.

SECTION: 'A'

Q.1 The decimal representation of a rational number is $\frac{p}{q}$ a terminating decimal only if for non-negative integers m and n prime factors of q are of the form :

- (A) $2^m \times 3^n$ (B) $3^m \times 5^n$ (C) $3^n \times 7^n$ (D) $2^m \times 5^n$

Q.2 In the given figure, the number of zeroes of the polynomial $f(x)$ are :

- (A) 1
(B) 2
(C) 3
(D) 4

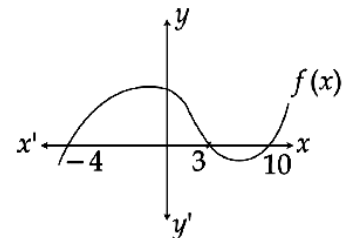

Q.3 If in triangles ABC and EDF $\frac{AB}{DE} = \frac{BC}{FD}$, then they will be similar when :

- (A) $\angle B = \angle E$ (B) $\angle A = \angle D$ (C) $\angle B = \angle D$ (D) $\angle A = \angle F$

Q.4 If $\sin \alpha = \frac{1}{2}$ and $\cos \beta = \frac{1}{2}$, then $\alpha + \beta$ is:

- (A) 0° (B) 30° (C) 90° (D) 60°

Q.5 If two positive integers p and q can be expressed as $p = a^3b^2$ and $q = ab^3c^2$, a, b, c being prime numbers, then LCM(p, q) is :

- (A) $a^3b^3c^3$ (B) $a^2b^2c^2$ (C) $a^3b^3c^2$ (D) ab^2

Q.6 If $am \neq bl$, then the pair of equations $ax + by = c$; $lx + my = n$:

- (A) has a unique solution (B) has no solution
(C) has infinitely many solutions (D) may or may not have a solution

- Q.7 If $A + B = 90^\circ$, $\cot B = \frac{3}{4}$ then $\tan A$ is equal to:
 (A) $\frac{5}{3}$ (B) $\frac{1}{3}$ (C) $\frac{3}{4}$ (D) $\frac{1}{4}$
- Q.8 Mode is the value of the variable which has :
 (A) maximum frequency (B) minimum frequency
 (C) mean frequency (D) middle most frequency

SECTION – B

- Q.9 HCF and LCM of two numbers is 9 and 459 respectively. If one of the number is 27, find the other number.
- Q.10 Form a quadratic polynomial whose zeroes are $3 + \sqrt{2}$ and $3 - \sqrt{2}$.
- Q.11 In the given figure, if $AD = x$, $DB = x - 2$, $AE = x + 2$ and $EC = x - 1$ and also $DE \parallel BC$, find the value of 'x'.

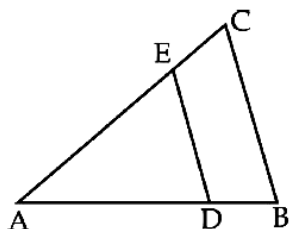

- Q.12 If $\tan A = \frac{5}{12}$, find the value of $(\sin A + \cos A) \cdot \sec A$
- Q.13 One zero of the polynomial $x^2 - 2x - (7p + 3)$ is -4 , find the value of p and the other zero.
- Q.14 Find the mean for the following data :

Classes	20 - 30	30 - 40	40 - 50	50 - 60	60 - 70	70 - 80
Frequency	5	6	10	5	3	1

OR

Convert the following frequency distribution to a more than type' cumulative frequency distribution.

Marks obtained	0 - 20	20 - 40	40 - 60	60 - 80	80 - 100
No. of Students	5	9	12	8	6

SECTION – C

- Q.15 ABCD is a trapezium in which $AB \parallel DC$ and its diagonals intersect each other at the point O. Show that $\frac{AO}{BO} = \frac{CO}{DO}$

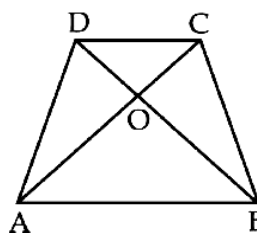

- Q.16 If the polynomial $x^3 + 2x^2 + ax + b$ has factors $x + 1$ and $x - 1$, find the values of a and b .
- Q.17 Sita takes 35 seconds to pack and label a box. For Ram, the same job takes 42 seconds and for Geetha, it takes 28 seconds. If they all start using labelling machines at the same time, after how many seconds will they be using the labelling machines together?

OR

Find the H.C.F. of 1620, 1725 and 255 by Euclids Division Algorithm.

- Q.18 Evaluate the following :
- $$2(\cos^4 60^\circ + \sin^4 60^\circ) - (\tan^2 60^\circ + \cot^2 45^\circ) + 3\sec^2 30^\circ$$
- Q.19 Divide $p(x) = x^4 - 5x + 6$ by $g(x) = 2 - x^2$ and verify the result by division algorithm.
- Q.20 2 Men and 7 boys can do a piece of work in 4 days. It is done by 4 men and 4 boys in 3 days. How long would it take for one man or one boy to do it ?

OR

Solve the following pair of equations for x and y :

$$\frac{10}{x+y} + \frac{2}{x-y} = 4 ; \quad \frac{15}{x+y} - \frac{5}{x-y} = -2$$

- Q.21 If the median for the following frequency distribution is 28.5, find the values of x and y :

Classes	Frequencies
0 - 10	5
10 - 20	x
20 - 30	20
30 - 40	15
40 - 50	y
50 - 60	5
	60

- Q.22 In the given figure, $AD \perp BC$ and $BD = \frac{1}{3}CD$. Prove that $2AC^2 = 2AB^2 + BC^2$

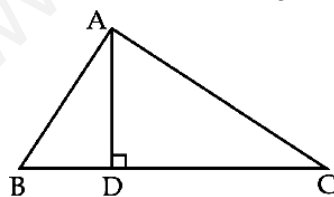

OR

In $\triangle ABC$, XY is parallel to BC and it divides $\triangle ABC$ into two parts of equal area, prove that

$$\frac{BX}{AB} = \frac{\sqrt{2}-1}{\sqrt{2}}$$

- Q.23 Evaluate the following without using trigonometric tables:

$$\frac{\sec^2 54^\circ - \cot^2 36^\circ}{\cos^2 57^\circ - \tan^2 33^\circ} + 2\sin^2 38^\circ \sec^2 52^\circ - \sin^2 45^\circ$$

Q.24 Find the mode for the following data :

Classes	Frequency
10 - 15	30
15 - 20	40
20 - 25	75
25 - 30	35
30 - 35	25
35 - 40	15

SECTION - D

Q.25 Prove that $\sqrt{3}$ is an irrational number. Hence show that $\frac{3}{2\sqrt{3}}$ is also irrational.

Q.26 Solve the following pair of equations graphically $2x + y = 8$; $x + 1 = 2y$. Also, find the co-ordinates of the points where the lines represented by the above equations meets the x-axis.

Q.27 Prove that : $\frac{\tan A}{1 - \cot A} + \frac{\cot A}{1 - \tan A} = 1 + \sec A \cos ecA$.

Q.28 The mean of the following frequency distribution is 50 and the sum of all the frequencies is 120. Find the missing frequencies x and y :

Classes	Frequencies
0 - 20	17
20 - 40	x
40 - 60	32
60 - 80	y
80 - 100	19
Total	120

Q.29 Find the other zeroes of the polynomial $p(x) = 6x^4 + x^3 - 27x^2 - 2x + 30$ if two of its zeroes are $\sqrt{2}$ and $-\sqrt{2}$.

OR

A train moving with uniform speed for a certain distance takes 6 hours less if its speed be increased by 6 km/hour. It would have taken 6 hours more, had its speed been decreased by 4 km/hr. Find the distance travelled of the journey and the speed of the train.

Q.30 Prove that the ratio of the areas of two similar triangles is equal to the ratio of the square of their corresponding sides.

OR

Prove that in a right-angled triangle, the square of the hypotenuse is equal to the sum of the squares on the other two sides.

Q.31 Prove that : $\sqrt{\frac{\sec \theta - 1}{\sec \theta + 1}} + \sqrt{\frac{\sec \theta + 1}{\sec \theta - 1}} = 2 \cos ec \theta$

Q.32 D and E are points on the sides CA and CB respectively of a triangle ABC right angled at C. Prove that $AE^2 + BD^2 = AB^2 + DE^2$

Q.33 Prove that : $\frac{\cot A + \cos ecA - 1}{\cot A - \cos ecA + 1} = \frac{1 + \cos A}{\sin A}$

DELHI PUBLIC SCHOOL
Indrapuram, Ghaziabad

Assignment Booklet
(Class - X : MATHS)

Q.34 Draw a cumulative frequency curve for the following frequency distribution by less than method:

Classes	Frequency
0 - 9	5
10 - 19	15
20 - 29	20
30 - 39	23
40 - 49	17
50 - 59	11
60 - 69	9
Total	100

www.studiestoday.com

MODEL TEST PAPER (SOLVED)
SUMMATIVE ASSESSMENT – II**(CLASS – X)****Time: 3hrs****M.M.:90****General Instructions:**

- (i) All questions are **compulsory**.
- (ii) The question paper consists of **34** questions divided into four **sections A, B, C and D**. **Section-A** comprises of **8** questions of **1 mark** each; **Section-B** comprises of **6** questions of **2 marks** each; **Section-C** comprises of **10** questions of **3 marks** each and **Section-D** comprises of **10** questions of **4 marks** each.
- (iii) Question numbers **1 to 8** in **Section-A** are multiple choice questions where you are required to select one correct option out of the given four.
- (iv) There is no overall choice.
- (v) Use of calculator is not permitted.

SECTION: 'A'

- Q.1 The roots of the quadratic equation $x^2 - 3x + 2 = 0$
(A) (1,-2) (B) (-1, 2) (C) (-1,-2) (D) (1,2)

- Q.2 In fig, two equal circles touch each other at T, if QP = 4.5 cm, then QR is:

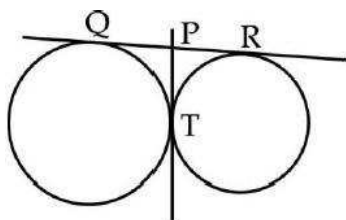

- (A) 9 cm (B) 18 cm (C) 15 cm (D) 13.5 cm
- Q.3 In given figure, $\angle BAC = 60^\circ$ and AB is a diameter, then $\angle CBD$ is :

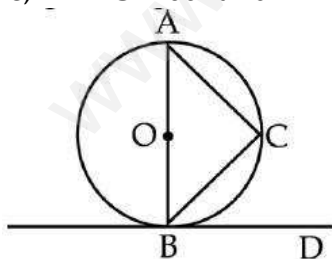

- (A) 60° (B) 30° (C) 45° (D) 80°
- Q.4 The shadow of a tower 100m high is $\frac{100}{\sqrt{3}}$ m . The angle of elevation of sun is
(A) 90° (B) 45° (C) 30° (D) 60°
- Q.5 Which of the following cannot be the probability of an event:
(A) $\frac{2}{3}$ (B) 0.7 (C) 15% (D) 1.5

- Q.21 The dimensions of a metallic cuboid are $100\text{cm} \times 80\text{cm} \times 64\text{cm}$. It is melted and recast into a cube. Find the surface area of the cube.
- Q.22 A hemispherical bowl of internal diameter 18cm contains a liquid. This liquid is to be filled into cylindrical shaped bottles of diameter 3cm and height 4cm . How many bottles are necessary to empty the bowl?
- Q.23 Which term of the A.P. $3, 15, 27, 39, \dots$ is 132 more than its 54^{th} term?
- Q.24 A toy is in the form of a cone mounted on a hemisphere of same radius. The diameter of the base of the cone is 18cm and its height is 12cm . Calculate the total surface area of the toy. (Use $\pi = 3.14$)

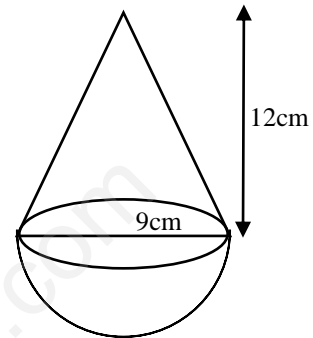

SECTION – D

- Q.25 The denominator of a fraction is two more than its numerator. If the sum of the fraction and its reciprocal is $\frac{34}{15}$, find the fraction.
- Q.26 A two digit number is such that the product of its digits is 18 . When 63 is subtracted from the number, the digits interchange their places. Find the number.
- Q.27 Dinesh, a juice-seller has set up the juice shop. He has two types of glasses in the shape of a frustum of a cone, whose inner diameter of the bottom of a frustum of a cone is 10cm and that of the top is 6cm and height 5cm . (Use $\pi = 3.14$)
- A glass with a plane bottom A glass with conical raised bottom of height 1.5cm

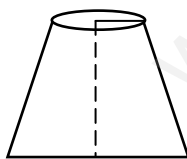

Type A

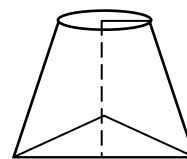

Type B

He decided to serve the customers in A type of glasses.

- (i) Find the volume of glass of type A.
- (ii) Which glass has the minimum capacity?
- (iii) By choosing a glass of type A, which value is depicted by juice seller Dinesh?
- Q.28 Draw a circle of radius 5cm . Mark a point A which is 8cm away from its centre O, construct the tangents AB and AC. Measure the length of AB and AC.
- Q.29 Construct ΔPQR , $QR = 6.5\text{cm}$, $\angle Q = 30^\circ$ and $PQ = 5\text{cm}$. Construct another Δ whose sides are $\frac{2}{3}$ times the corresponding sides of the ΔPQR .

- Q.30 The angle of elevation of a jet plane from a point A on the ground is 60° . After a flight of 30 seconds, the angle of elevation changes to 30° . If the jet plane is flying at a constant height of $3000\sqrt{3}$ m, find the speed of the jet plane.
- Q.31 One card is drawn out from a well shuffled deck of 52 playing cards. Calculate the probability that the card will
- | | |
|----------------------|---------------------|
| (i) be an ace | (ii) be a face card |
| (iii) not be a queen | (iv) a spade |
- Q.32 Find the point of the x-axis which is equidistant from the points (5, 4) and (-2, 3). Also find the area of triangle formed by these points.
- Q.33 An open container made up of a metal sheet is in the form of a frustum of a cone of height 8cm with radii of its lower and upper ends as 4cm and 10cm respectively. Find the cost of metal used, if it costs Rs 5 per 100 cm^2 .
- Q.34 In the given figure, a semicircle is drawn on AB as diameter, and O is center. Semicircular flower beds are formed on AO and OB as diameters. If AB is 28 m, find the area of the shaded region.

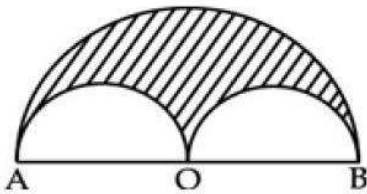

SOLUTION

SUMMATIVE ASSESSMENT – II

SECTION: 'A'

[1×8=8]

- Q.1 D
- Q.2 A
- Q.3 A
- Q.4 D
- Q.5 D
- Q.6 D
- Q.7 C
- Q.8 C

SECTION: 'B'

Q.9 Real & Equal Roots if $b^2 - 4ac = 0$ [1]

$4 - 12k = 0, \quad K = \frac{1}{3}$ [1]

Q.10 $6x^2 + 7x - 5 = 0$
 $6x^2 + 10x - 3x - 5 = 0$ [½]

$2x(3x + 5) - (3x + 5) = 0$ [½]

$(2x - 1)(3x + 5) = 0$ [½]

$x = \frac{1}{2}, -\frac{5}{3}$ [½]

Q.11 Given Diameter MN Tangents AB & CD

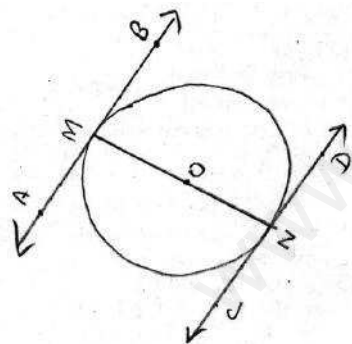

$\angle OMB = 90^\circ$ ----- (1)

$\angle OND = 90^\circ$ ----- (2) [1]

(Tangents form a right angle at point of contact with the radius of)

Adding equation (1) & (2)

$\angle OMB + \angle OND = 90^\circ$
 $\therefore AB \parallel CD$ [1]

(Co-interior angles on same side of transversal are)

Q.12 $\angle OAP = 90^\circ$
 $\angle OBP = 90^\circ$ (A tangents is perpendicular to the radius at the point of) ----- (i) [1]

In quad AOBP

$\angle OAP + \angle APB + \angle OBP + \angle AOB = 360^\circ$ (ASP)

$\angle APB + \angle AOB = 180^\circ$ (From equation (i)) [1]

\therefore quad ADBP is cyclic.

Q.13 Numbers not divisible by 3 = 20 [½]
Total outcomes = 30

Probability (E) = $\frac{\text{Numbers not divisible}}{\text{Total outcome}}$ [½]

$$P(E) = \frac{20}{30} = \frac{2}{3} \quad [1]$$

Q.14 Volume of sphere = Volume of cylinder

$$\frac{4}{3} \pi r_1^3 = \pi r_2^2 h \quad [½]$$

$$\frac{4}{3} \times 6 \times 6 \times 6 = 3 \times 3 \times h \quad [½]$$

$$\frac{4}{3} \times \frac{6^2 \times 6^2 \times 6^2}{3 \times 3} = h \quad [½]$$

$$32cm = h \quad [½]$$

SECTION: 'C'

Q.15 By Pythagoras theorem

$$(x+1)^2 = (x-1)^2 + (x)^2 \quad [½]$$

$$x^2 + 2x + 1 = x^2 - 2x + 1 + x^2$$

$$x^2 - 4x = 0 \quad [½]$$

$$x(x-4) = 0$$

either $x = 0$ or $x = 4$ [1]

$x = 0$ rejected

Sides of right triangle are 3cm, 4cm, 5cm. [1]

Q.16 $a_4 + a_8 = 24$ $a_6 + a_{10} = 44$

$$a + 3d + a + 7d = 24 \quad a + 5d + a + 9d = 44 \quad [1]$$

$$2a + 10d = 24 \quad 2a + 14d = 44$$

$$a + 5d = 12 \quad \text{-----(1)} \quad a + 7d = 22 \quad \text{-----(2)} \quad [½]$$

Subtracting equation (1) from (2)

$$2d = 10$$

$$d = 5 \quad [½]$$

substitute $d = 5$ in equation (1)

$$a + 5(5) = 12$$

$$a + 25 = 12 \quad a = 12 - 25 = -13 \text{ Ans.} \quad [½]$$

\therefore the first three terms are $-13, -8, -3$ [½]

Q.17 To prove $PR = QR$ [½]

Const: Join O to R

Proof: In $\triangle OPR$ & $\triangle OQR$

$OP = OQ$ (radii of same circle) [½]

$\angle OPR = \angle OQR = 90^\circ$ (tangent is \perp to radius at point of contact)

$OR = OR$ (Common) [½]

$\therefore \triangle OPR \cong \triangle OQR$ (RHS)

$\therefore PR = QR$ (cpct) [½]

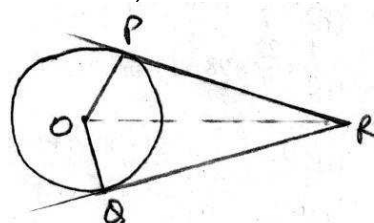

Q.18 In rt $\triangle ABD$ $\frac{AB}{BD} = \tan 30^\circ$
 $\frac{h}{x+20} = \frac{1}{\sqrt{3}}$
 $\sqrt{3}h = x+20$ ----- (1)

In rt $\triangle ABC$ $\frac{AB}{BC} = \tan 45^\circ$
 $\frac{h}{x} = 1$
 $h = x$ ----- (2)

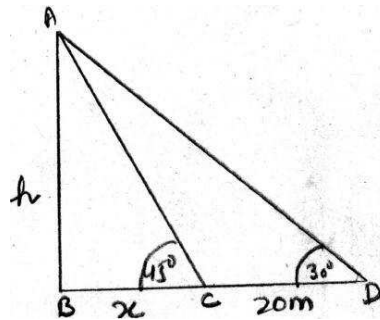

From (1) & (2)

$\sqrt{3}h = h + 20$ [1/2]
 $\sqrt{3}h - h = 20$
 $h = \frac{20}{\sqrt{3}-1} \times \frac{\sqrt{3}+1}{\sqrt{3}+1}$ [1]
 $h = \frac{20^{10}(\sqrt{3}+1)}{2}$ [1/2]

Height of chimney = $10(\sqrt{3}+1)m$

Q.19 Since $(7, -2)$ $(5, 1)$ & $(3, k)$ are collinear, \therefore area of triangle formed using these coordinates will be zero i.e. [1/2]

$\frac{1}{2}[7(1-k) + 5(k+2) + 3(-2-1)] = 0$ [1]
 $\Rightarrow \frac{1}{2}[7-7k+5k+10-6-3] = 0$ [1]
 $\Rightarrow \frac{1}{2}[8-2k] = 0$ [1]
 $\Rightarrow 8 = 2k$
 $k = 4$ Ans. [1/2]

Q.20 Let $A(1, 2)$ $A(4, 4)$ $C(x, 6)$ & $D(3, 5)$ are vertices of a parallelogram. Diagonals of a parallelogram bisect each other. [1]

\therefore Coordinates of midpoint of AC = Coordinates of midpoint of BD [1]
 $\therefore \left(\frac{1+x}{2}, \frac{2+6}{2}\right) = \left(\frac{4+3}{2}, \frac{y+5}{2}\right)$ [1]
 $\therefore \frac{1+x}{2} = \frac{7}{2}$ & $\frac{8}{2} = \left(\frac{y+5}{2}\right)$
 $\boxed{x=6}$ $\boxed{y=3}$ [1]

Q.21 V of cuboid = $100 \times 80 \times 64 =$ volume of cube
 $\therefore a^3 = 512000$ [1]
 $\Rightarrow a = 80\text{cm}$ [1]
 Now SA = $6a^2$
 $= 6 \times 80 \times 80$
 $= 38400\text{cm}^2$ [1]

Q.22 No. of bottles = $\frac{\text{Volume of hemishpere}}{\text{Volume of cylinder}}$

$$= \frac{\frac{2}{3} \times \pi \times 9 \times 9 \times 9}{\pi \times \frac{3}{2} \times \frac{3}{2} \times 4}$$
 [1½]

$$= \frac{2}{3} \times 9 \times 9 \times 9 \times \frac{2}{3} \times \frac{2}{3} \times \frac{1}{4}$$
 [½]
 $= 54 \text{ bottles}$

Q.23 A.P 3, 15, 27, 39.....
 $a = 3 \quad d = 15 - 3 = 12$ [1]
 $a_{54} = a + 53d \Rightarrow 3 + 53 \times 12$
 $= 3 + 636 = 639$
 $a_n = 639 + 132 = 771$ [½]
 $a + (n-1)d = 771$
 $3 + (n-1)12 = 771$ [½]
 $n-1 = \frac{768}{12} = 64$
 $n = 64+1 = (65^{\text{th}} \text{ term}) \text{ Ans.}$ [1]

Q.24 T.SA of Toy = C.SA of cone + C.SA of hemisphere
 $= \pi r l + 2\pi r^2 = \pi r(l + 2r)$ [1]
 $l = \sqrt{9^2 + 12^2} = \sqrt{81 + 144} = \sqrt{225}$ [1]
 $l = 15\text{cm}$
 T.SA = $3.14 \times 9(15+18)$
 $3.14 \times 9 \times 33 = 932.58\text{cm}^2$ [1]

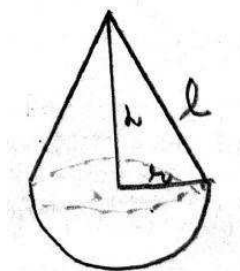

SECTION: 'D'

Q.25 Let Numerator = x [½]

Denominator = $x + 2$

According to the question

$$\frac{x}{x+2} + \frac{x+2}{x} = \frac{34}{15} \quad [1]$$

$$\frac{x^2 + x^2 + 4x + 4}{x^2 + 2x} = \frac{34}{15} \quad [1]$$

$$\frac{2(x^2 + 2x + 2)}{x^2 + 2x} = \frac{2 \times 17}{15} \quad [1]$$

$$(x^2 + 2x + 2)15 = 17(x^2 + 2x)$$

$$15x^2 + 30x + 30 = 17x^2 + 34x$$

$$0 = 2x^2 + 4x - 30$$

$$x^2 + 2x - 15 = 0$$

$$x^2 + 5x - 3(x + 5) = 0 \quad [½]$$

$$x = 3, -5$$

$$\text{Fraction} = \frac{3}{5} \quad [½]$$

Q.26 Let the digit at one's place = x

Let the digit at ten's place = y

Original No. = $10y + x$ [½]

Also $x \times y = 18$ [½]

$$y = \frac{18}{x} \quad \text{-----(1)} \quad [½]$$

On reversing the digits

New No. = $10x + y$

ATQ [½]

$$10y + x - 63 = 10x + y$$

$$y - x = 7 \quad \text{-----(2)} \quad [½]$$

Substitute eq. (1) in eq. (2)

$$\frac{18}{x} - x = 7 \quad [1]$$

$$18 - x^2 = 7x$$

$$x^2 + 7x - 18 = 0$$

$$x^2 + 9x - 2x - 18 = 0$$

$$x(x + 9) - 2(x + 9) = 0$$

$$(x - 2)(x + 9) = 0$$

Either $x = 2$ or $x = -9$ (rejected)

$$\text{The Original No} = 92 \left(\text{as } y = \frac{18}{2} = 9 \right) \quad [1]$$

- Q.27** (i) Volume of glass of type A

$$= \frac{1}{3}\pi(r_1^2 + r_2^2 + r_1r_2)h$$
 [1]

$$= \frac{1}{3} \times 3.14(3^2 + 5^2 + 15) \times 5$$

$$= \frac{1}{3} \times 3.14 \times (9 + 25 + 15) \times 5$$

$$= \frac{1}{3} \times 3.14 \times 49 \times 5 = 256.43 \text{ cm}^3$$
 [1]
- (ii) Glass type B will have minimum capacity. [1]
 (iii) By choosing a glass of type A,
 Honesty of the juice seller Dinesh is depicted [1]

- Q.28** Construction of circle [1/2]
 Marking OA = 8cm [1/2]
 Finding radius [1]
 Construction of circle [1/2]
 Tangents [1/2]
 Measuring tangent AB & AC [1]

- Q.29** Construction of ΔPQR [1]
 Division of one side in ratio 2/3 [1]
 Construction of $\Delta P'QR' \sim \Delta PQR$ [1]
 Labelling [1]

- Q.30** In rt ΔABC

$$\frac{AB}{BC} = \tan 60$$

$$BC = \frac{3000\sqrt{3}}{\sqrt{3}}$$

$$BC = 3000 \text{ m}$$

$$\text{In rt } \Delta DCE \frac{DE}{CE} = \tan 30^\circ$$

$$\frac{3000\sqrt{3}}{3000 + x} = \frac{1}{\sqrt{3}}$$

$$9000 = 3000 + x$$

$$6000 = x$$

$$\text{Speed} = \frac{\text{Distance}}{\text{Time}} = \frac{6000}{30} = 200 \text{ m/sec}$$

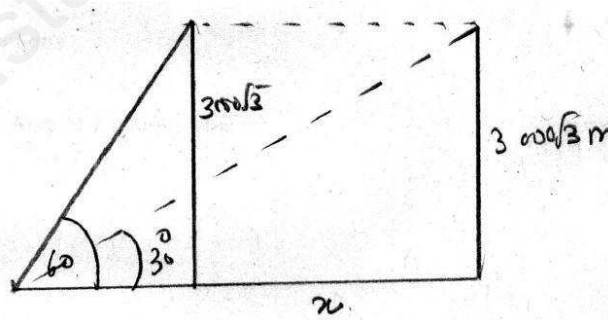

- Q.31** (i) $P(\text{an ace}) = \frac{\text{No. of Aces}}{\text{Total outcome}} = \frac{4}{52} = \frac{1}{13}$ [1]
- (ii) $P(\text{Face card}) = \frac{\text{No. of Face Card}}{\text{Total outcome}} = \frac{12}{52} = \frac{3}{13}$ [1]
- (iii) $P(\text{not a queen}) = \frac{\text{No. of Cards without queen}}{\text{Total outcome}} = \frac{52-4}{52} = \frac{48}{52} = \frac{12}{13}$ [1]

OR

$$1 - P(\text{queen})$$

$$1 - \frac{4}{52} = 1 - \frac{1}{13} = \frac{12}{13}$$

$$(iv) \quad P(\text{A spade}) = \frac{\text{Total no. of spade}}{\text{Total outcome}} = \frac{13}{52} = \frac{1}{4} \quad [1]$$

Q.32 Let P(x, 0) is equidistant from A(5, 4) & B(-2, 3)

$$\therefore AP = BP \quad [1]$$

$$\therefore AP^2 = BP^2$$

$$(5-x)^2 + (4-0)^2 = (-2-x)^2 + (3-0)^2 \quad [1/2]$$

$$25 + x^2 - 10x + 16 = 4 + 4x + x^2 + 9$$

$$0 = 14x + 13 - 41 \quad [1]$$

$$0 = 14x - 28$$

$$14x = 28$$

$$x = 2$$

$$\text{Area of } \Delta PAB = \frac{1}{2} [2(3-4) - 2(4) + 5(-3)] \quad [1]$$

$$= \frac{1}{2} [-2 - 8 - 15] = \frac{1}{2} [-25] = \left(\frac{25}{2}\right) \text{ square units } (-ve \text{ rejected}) \quad [1/2]$$

Q.33 $r_1 = 10\text{cm}$, $r_2 = 4\text{cm}$

Metal used = C.S.A + Area of 1 bottom base

$$= \pi l(r_1 + r_2) + \pi r_2^2 \quad [1]$$

$$l = \sqrt{8^2 + (10-4)^2} = \sqrt{64 + 36} = 10\text{cm} \quad [1]$$

$$\pi [l(r_1 + r_2) + r_2^2]$$

$$3.14 [10(14) + 16] \quad [1]$$

$$3.14 [140 + 16]$$

$$3.14(156) = 489.84 \text{ cm}^2$$

$$\text{Cost of metal used} = 489.84 \times \frac{5}{100} = \text{Rs. } 24.49 \quad [1]$$

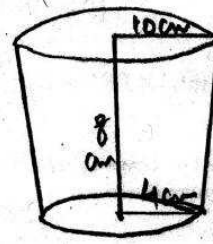

Q.34 Area of shaded portion = Area of Big semicircle - Area of 2 small semicircles. [1]

$$\Rightarrow \frac{1}{2} \pi (14)^2 - 2 \times \frac{1}{2} \pi (7)^2 \quad [1]$$

$$\frac{1}{2} \pi [(14)^2 - 2(49)]$$

$$\frac{1}{2} \times \frac{22}{7} \times [196 - 98] \quad [1]$$

$$\frac{1}{2} \times \frac{22}{7} \times 98 = 154 \text{ m}^2 \quad [1]$$

MODEL TEST PAPER (UNSOLVED)
SUMMATIVE ASSESSMENT – II

Time: 3hrs

(CLASS – X)

M.M.:90

General Instructions:

- (i) All questions are **compulsory**.
- (ii) The question paper consists of **34** questions divided into four **sections A, B, C and D**. **Section-A** comprises of **8** questions of **1 mark** each; **Section-B** comprises of **6** questions of **2 marks** each; **Section-C** comprises of **10** questions of **3 marks** each and **Section-D** comprises of **10** questions of **4 marks** each.
- (iii) Question numbers **1 to 8** in **Section-A** are multiple choice questions where you are required to select one correct option out of the given four.
- (iv) There is no overall choice.
- (v) Use of calculator is not permitted.

SECTION: 'A'

- Q.1 In the quadratic equation $kx^2+5x+k=0$, if the discriminant is 9, then the value of k is:
(A) ± 2 (B) ± 4
(C) 2 only (D) 4
- Q.2 To draw a pair of tangents to a circle which are inclined to each other at an angle of 70° , it is required to draw tangents at the end points of those two radii of the circle which have the angle between them equal to:
(A) 110° (B) 70° (C) 80° (D) 120°
- Q.3 To construct a similar triangle to ΔPQR with its sides $\frac{5}{2}$ of the corresponding sides of ΔPQR a ray QX is drawn as shown and points Q_1, Q_2, \dots, Q_5 are located at equal distances on QX , then R is joined to:

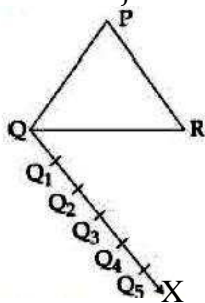

- (A) Q_5 (B) Q_2 (C) Q_3 (D) Q_4
- Q.4 In the adjoining figure. If the angle of depression is 60° and $AB = 10\sqrt{3}$ m, then the height of the tower is:

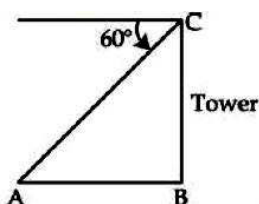

- (A) $20\sqrt{3}$ m (B) 10m
(C) 30m (D) $30\sqrt{3}$ m

- Q.17 In the fig, tangents PS and PT are drawn to a circle with centre O such that $\angle SPT = 120^\circ$. Prove that $OP = 2PS$.

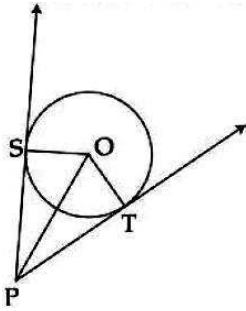

- Q.18 The upper part of a tree broken by the wind makes an angle of 60° with the ground and the distance from the foot to the point where the top of the tree meets the ground is 20m. What was the height of the tree?
- Q.19 A parallelogram is drawn on the co-ordinate plane with points A (- 4, 6), B (0, 2), C(-4, 0) and D (- 8, 2). Find the length of the two diagonals. Which diagonal is greater?
- Q.20 The point R divides the line segment AB, where A(-4, 0) and B (0, 6) are such that $AR = \frac{3}{4} AB$. Find the co-ordinates of R.
- Q.21 The radius and height of a right circular cone are in the ratio 5 : 12. If its volume is 314cm^3 , find its slant height. (Use $\pi = 3.14$)
- Q.22 A hemispherical bowl of internal diameter 18cm contains a liquid. This liquid is to be filled into cylindrical shaped bottles of diameter 3cm and height 4cm. How many bottles are necessary to empty the bowl?
- Q.23 A toy is in the form of a cone mounted on a hemisphere of same radius. The diameter of the base of the cone is 18 cm and its height is 12 cm. Calculate the total surface area of the toy. (Use $\pi = 3.14$)
- Q.24 In a garden, there are 23 rose plants in the first row, 21 are in the 2nd, 19 in 3rd row and so on. There are 5 plants in the last row. How many rows are there of rose plants? Also find the total number of rose plants in the garden.

SECTION – D

- Q.25 The denominator of a fraction is one more than twice its numerator. If the sum of the fraction and its reciprocal is $2\frac{16}{21}$, find the fraction.
- Q.26 A motor boat whose speed is 18 km per hour in still water takes 1 hour more to go 24 km upstream than to return downstream to the same spot. Find the speed of the stream.
- Q.27 Hari, a cold milk seller has set up his cold milk shop. He has two types of glasses in the shape of a frustum of a cone whose radii of the ends of frustum are 6cm and 3cm to serve the customers. The height of the glass is 10cm.

A glass with a plane bottom

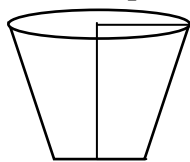

Type A

A glass with hemispherical raised bottom

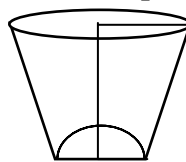

Type B

He decided to serve the customers in A type of glasses.

- (iv) Find the volume of glass of type A.
- (v) Which glass has the less capacity?
- (vi) By choosing a glass of type A, which value is depicted by cold milk seller Hari?

- Q.28 Draw a triangle ABC with sides $BC=7$ cm, $\angle B=45^\circ$, $\angle A=105^\circ$. Then construct another triangle whose sides are $\frac{3}{4}$ times the corresponding sides of ΔABC .
- Q.29 Construct tangents to a circle of radius 3.5cm from a point on the concentric circle of radius 5.5cm and measure their lengths.
- Q.30 An aeroplane at an altitude of 200metres observes the angles of depression of two opposite points on the two banks of a river to be 45° and 60° . Find the width of the river.
- Q.31 The king, queen and jack of clubs are removed from a pack of 52 playing cards and then the remaining pack is well shuffled. One card is selected from the remaining cards. Find the probability of getting
- (i) a heart (ii) a king (iii) a club (iv) a black card
- Q.32 Find the point on the x-axis which is equidistant from the points (5, 4) and (-2, 3). Also find the area of triangle formed by these points.
- Q.33 A solid is in the form of a cylinder with hemispherical ends. The total height of the solid is 19 cm and the diameter of cylindrical and hemispherical parts is 7 cm. Find the total surface area of the solid.
- Q.34 In the given figure, ABC is a right angled triangle right angled at A. Semi - circles are drawn on AB, AC and BC as diameters. Find the area of the shaded region.

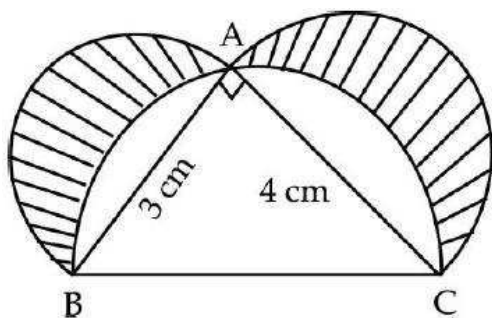

=====

~~~~~

=====

**IMPORTANT FORMULAE & DEFINITIONS**

1. **Natural Numbers** : - All counting numbers starting from 1 and so on are called natural numbers.

$$N = \{1, 2, 3, \text{-----}\}$$

2. **Whole Numbers** : All natural numbers and zero together form the set of whole numbers.

$$W = \{0, 1, 2, \text{-----}\}$$

3. **Real Numbers** :- Rational numbers and irrational numbers taken together form the real numbers.

4. **Rational Numbers** :- A number of the form  $\frac{p}{q}$  where p and q are both integers

and  $q \neq 0$  is called rational numbers. E.g.  $\frac{2}{3}$ ,  $\frac{-4}{5}$ .

5. **Irrational Numbers** :- Numbers which are not rational numbers are called irrational numbers. For e.g.  $\sqrt{2}$ ,  $\sqrt{3}$  etc.

6. **Prime Numbers** :- The numbers which have only two factors i.e. 1 and the number itself are called Prime No's for eg. 2, 3, 5, 7, ----- etc.

**Note** :- 1 is not considered as a prime number. '1' is a unique number.

7. **Coprime Numbers** :- The numbers having only 1 as a common factor are called coprime numbers. For ex. 4 and 15

8. **Twin Numbers** :- Two prime numbers are known as twin primes if there is only one composite number between them for ex :- 3 and 5, 5 and 7.

9. **Composite Numbers** :- The numbers which are not prime are called composite numbers.

Smallest composite number is 4.

10. **Integers** : - All negative numbers, positive numbers including zero are called integers. For ex -

$$\{\text{-----} - 7, - 6, - 5, - 4, - 3, - 2, - 1, 0, 1, 2, 3, 4, 5, 6, 7 \text{-----}\}$$

**POLYNOMIALS** :-

1.  $(a + b)^2 = a^2 + 2ab + b^2$

2.  $(a - b)^2 = a^2 - 2ab + b^2$

3.  $(a^2 - b^2) = (a - b)(a + b)$
4.  $(a + b + c)^2 = a^2 + 2ab + 2bc + 2ca + c^2 + b^2$
5.  $(a + b)^3 = a^3 + 3ab(a + b) + b^3 = a^3 + b^3 + 3ab^2 + 3a^2b.$
6.  $(a - b)^3 = a^3 - 3ab(a - b) - b^3 = a^3 - b^3 - 3a^2b + 3ab^2.$
7.  $a^3 + b^3 = (a + b)^3 - 3ab(a + b) = (a + b)(a^2 + b^2 - ab)$
8.  $a^3 - b^3 = (a - b)^3 + 3ab(a - b) = (a - b)(a^2 + b^2 + ab)$
9.  $a^3 + b^3 + c^3 - 3abc = (a + b + c)(a^2 + b^2 + c^2 - ab - bc - ca)$
10.  $a^3 + b^3 + c^3 = 3abc,$  if  $a + b + c = 0$

**QUADRATIC EQUATION :-**

1. **General Form** : -  $ax^2 + bx + c = 0$  where  $a \neq 0$  sum of the roots =  $-\frac{b}{a}$   
Product of the roots =  $\frac{c}{a}$

2. **Formation of Quadratic Eq<sup>n</sup>** : -  
 $x^2 - (\text{sum of the roots})x + \text{Product of roots} = 0$

3. **Solution of Quadratic Eq<sup>n</sup>** : -

(i) Factorisation

(ii) Discriminant Method

Where Discriminant (D) =  $b^2 - 4ac$

then solution of equation is given by  $x = \frac{-b \pm \sqrt{b^2 - 4ac}}{2a}$

4. **Conditions of Roots of Eq<sup>n</sup>** : -

(i)  $D > 0 \Rightarrow$  Equation has Real and Distinct Roots

(ii)  $D = 0 \Rightarrow$  Real and Equal Roots

(iii)  $D < 0 \Rightarrow$  Non Real Roots

5. **Linear Equations** : - General Form : -  $ax + by + c = 0$   
System of Linear Equations

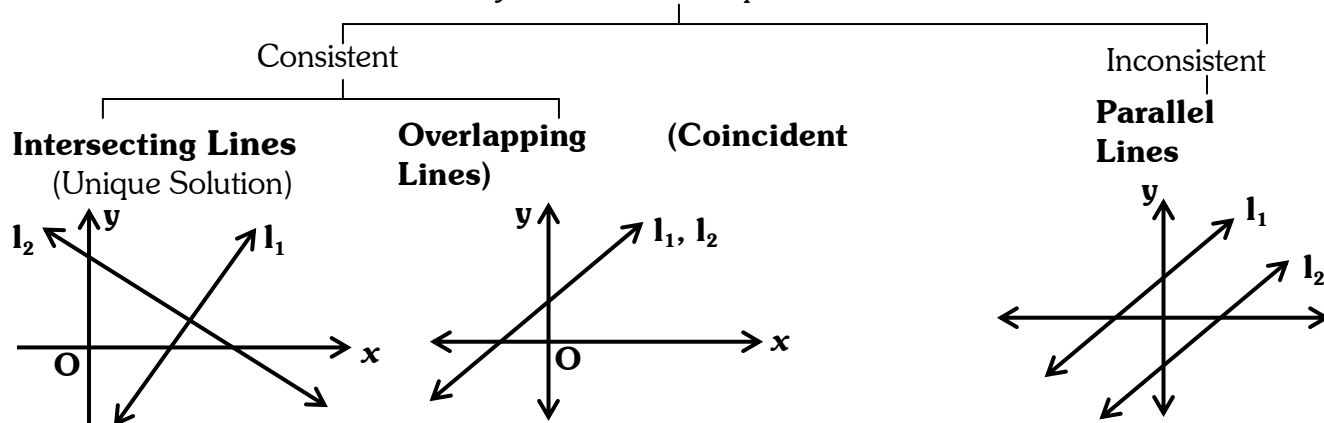

**6. Conditions of System of Eq<sup>n</sup> :-**

Two equations given by  $a_1x + b_1y + c_1 = 0$

$$a_2x + b_2y + c_2 = 0$$

May have (i) Unique Solution if  $\frac{a_1}{a_2} \neq \frac{b_1}{b_2}$

(ii) No Solution if  $\frac{a_1}{a_2} = \frac{b_1}{b_2} \neq \frac{c_1}{c_2}$

(iii) Infinitely many Sol<sup>n</sup> if  $\frac{a_1}{a_2} = \frac{b_1}{b_2} = \frac{c_1}{c_2}$

**SOLUTION BY ALGEBRAIC METHOD :-**

**1. Substitution Method**

**2. Elimination Method**

**3. Cross Multiplication Method**

Consider the eq<sup>n</sup>s  $a_1x + b_1y + c_1 = 0$

$$a_2x + b_2y + c_2 = 0$$

$$\frac{x}{\begin{matrix} b_1 & \nearrow & c_1 \\ b_2 & \searrow & c_2 \end{matrix}} = \frac{y}{\begin{matrix} c_1 & \nearrow & a_1 \\ c_2 & \searrow & a_2 \end{matrix}} = \frac{1}{\begin{matrix} a_1 & \nearrow & b_1 \\ a_2 & \searrow & b_2 \end{matrix}}$$

**IMPORTANT POINTS FOR WORD PROBLEMS :-**

**1. Speed :-**

(i) Downstream speed = Speed of boat in still water + speed of stream

(ii) Upstream speed = Speed of boat in still water – speed of stream

**2. Work :-** If a person can complete a work in x days then person's one day's work

$$\text{is } \frac{1}{x}$$

**ARITHMETIC PROGRESSION :-**

Here a = First term of series

d = Common difference

So A.P. = a, a + d, a + 2d, a + 3d + \_\_\_\_\_.

So, A.P. can be defined as a sequence obtained on adding the same quantity to the particular number and so on.

1. **Condition of A. P.** :- Diff of 2<sup>nd</sup> & 1<sup>st</sup> term = Diff of 3<sup>rd</sup> & 2<sup>nd</sup> term

2. **N<sup>th</sup> Term** :-  $T_n = a + (n - 1)d$

3. **Sum to n terms** :-  $S_n = \frac{n}{2} [2a + (n - 1)d]$

OR

$$S_n = \frac{n}{2} [a + l]$$

4. **Finding the n<sup>th</sup> Term from end** :-  $l_n = l - (n - 1)d$

Where l = last term

~~~~~  
COORDINATE GEOMETRY :- A (x_1, y_1) & B (x_2, y_2)

1. **Distances Formula** :- $\sqrt{(x_2 - x_1)^2 + (y_2 - y_1)^2}$

2. **Mid Point Formula** :- $\left(\frac{x_1 + x_2}{2}, \frac{y_1 + y_2}{2} \right)$

3. **Section Formula** :- $\left(\frac{m_1x_2 + m_2x_1}{m_1 + m_2}, \frac{m_1y_2 + m_2y_1}{m_1 + m_2} \right)$

Where $m_1 : m_2$ are the ratio of division.

~~~~~  
**CONDITIONS TO PROVE ANY FIGURE TO BE A** :-

1. **Rectangle**:- (i) Opp sides equal

(ii) Diagonals equal

2. **Parallelogram**:- (i) Opp sides equal

(ii) Diagonals not equal

3. **Rhombus**:- (i) All sides equal

(ii) Diagonals not equal

4. **Square**:- (i) All sides equal

(ii) Diagonals equal

5. **Right Angled Triangle** :- Prove the Pythagoras Theorem.

Square of one side = Sum of the square of other two sides.

6. **Collinear Points**:-  $AB + BC = CA$  OR

Using section formula, prove the ratio of division ( $m_1 : m_2$ ) = 1 : 1

OR

$$\text{area } (\Delta ABC) = 0$$

**POINTS OF INTERSECTION OF :-**

- |                                                                                               |                                                                                                                |
|-----------------------------------------------------------------------------------------------|----------------------------------------------------------------------------------------------------------------|
| <p><b>1. <u>Medians</u></b>:- Centroid</p> <p><b>3. <u>Angle Bisectors</u></b>:- Incentre</p> | <p><b>2. <u>Perpendicular bisectors</u></b>:- Circumcentre</p> <p><b>4. <u>Altitudes</u></b>:- Orthocentre</p> |
|-----------------------------------------------------------------------------------------------|----------------------------------------------------------------------------------------------------------------|

~~~~~

TRIGONOMETRY:-

$$\sin \theta = \frac{\text{Perpendicular}}{\text{Hypotenuse}} = \frac{P}{H}$$

$$\cos \theta = \frac{B}{H}$$

$$\tan \theta = \frac{\sin \theta}{\cos \theta} = \frac{P}{B}$$

$$\sec \theta = \frac{H}{B}$$

$$\operatorname{cosec} \theta = \frac{H}{P}$$

$$\cot \theta = \frac{B}{P} = \frac{\cos \theta}{\sin \theta}$$

- (i)** $\sin^2\theta + \cos^2\theta = 1$
- (ii)** $1 + \tan^2\theta = \sec^2\theta$
- (iii)** $1 + \cot^2\theta = \operatorname{cosec}^2\theta$

Angles	sinθ	cosθ	tanθ	cosecθ	secθ	cotθ
0°	0	1	0	n.d	1	n.d
30°	$\frac{1}{2}$	$\frac{\sqrt{3}}{2}$	$\frac{1}{\sqrt{3}}$	2	$\frac{2}{\sqrt{3}}$	$\sqrt{3}$
45°	$\frac{1}{\sqrt{2}}$	$\frac{1}{\sqrt{2}}$	1	$\sqrt{2}$	$\sqrt{2}$	1
60°	$\frac{\sqrt{3}}{2}$	$\frac{1}{2}$	$\sqrt{3}$	$\frac{2}{\sqrt{3}}$	2	$\frac{1}{\sqrt{3}}$
90°	1	0	n.d	1	n.d	0

Complementary Angles :-

- | | |
|---|--|
| <p>(i) $\sin (90 - \theta) = \cos \theta$</p> <p>(iii) $\tan (90 - \theta) = \cot \theta$</p> <p>(v) $\operatorname{cosec} (90 - \theta) = \sec \theta$</p> | <p>(ii) $\cos (90 - \theta) = \sin \theta$</p> <p>(iv) $\cot (90 - \theta) = \tan \theta$</p> <p>(vi) $\sec (90 - \theta) = \operatorname{cosec} \theta$</p> |
|---|--|
- ~~~~~

AREAS & VOLUMES :-**Symbols Used :-**

l = Length

b = Breadth

h = Height

 θ = Angle

r = Radius

'l' = Slant Height

1. **Triangle :-** (i) $\text{Area} = \frac{1}{2} \times \text{Base} \times \text{Height}$
 (ii) $\text{Area of Equilateral } \Delta = \frac{\sqrt{3}}{4} (\text{side})^2$

2. **Square :-** (i) $\text{Area} = \text{Side} \times \text{Side}$
 (ii) $\text{Perimeter} = 4 \times \text{Side}$
 (iii) $\text{Diagonal} = \sqrt{2} \times \text{Side}$

3. **Rectangle :-** (i) $\text{Area} = \text{Length} \times \text{Breadth}$
 (ii) $\text{Perimeter} = 2 (L + B)$
 (iii) $\text{Diagonal} = \sqrt{L^2 + B^2}$

4. **Circle :-** (i) $\text{Circumference} = 2\pi r$
 (ii) $\text{Area} = \pi r^2$

5. **Sector of Circle :-** (i) $\text{Area} = \frac{\pi r^2 \theta}{360^\circ}$
 (ii) $\text{Length of arc} = \frac{2\pi r \theta}{360^\circ}$

6. **Area of minor Segment :-** $\frac{1}{2} r^2 \left[\frac{\theta \pi}{180^\circ} - \sin \theta \right]$

7. **Area of Ring :-** $\pi (R^2 - r^2)$

Where R = External Radius

r = Internal Radius

8. **Area of Semicircle :-** $\frac{\pi r^2}{2}$

9. **Cuboid :-** $\text{Volume} = l \times b \times h$

$$\text{Area of four walls} = 2h (l + b)$$

$$\text{Total Surface Area} = 2 (lb + bh + hl)$$

10. **Cube :-** $\text{Volume} = (\text{Side})^3$

$$\text{Total Surface Area} = 6 \times (\text{side})^2$$

11. **Cylinder** :- Volume = $\pi r^2 h$
Curved Surface Area = $2 \pi r h$
Total Surface Area = $2 \pi r (r + h)$
12. **Cone** :- Volume = $\frac{1}{3} \pi r^2 h$
Curved Surface Area = $\pi r l$
Total Surface Area = $\pi r (r + l)$
Slant Height = $\sqrt{r^2 + h^2}$
13. **Frustrum Of Cone** :- Volume = $\frac{1}{3} \pi h (r_1^2 + r_2^2 + r_1 r_2)$
Where r_1 and r_2 are the radius of the circles at top and bottom.
14. **Sphere** :- Volume = $\frac{4}{3} \pi r^3$
Total Surface Area = $4 \pi r^2$
15. **Hemisphere** :- Volume = $\frac{2}{3} \pi r^3$
Curved Surface Area = $2 \pi r^2$
Total Surface Area = $3 \pi r^2$
16. **Parallelogram** :- Area = Base \times Height
17. **Rhombus** :- Area = $\frac{1}{2} \times$ Diagonal₁ \times Diagonal₂
18. **Trapezium** :- Area = $\frac{1}{2} \times$ Sum of Parallel Side \times Height

~~~~~  
**STATISTICS :-**

**Arithmetic Mean :-**

1. **Direct Method** :-  $\bar{x} = \frac{\sum f_i x_i}{\sum f_i}$
2. **Assumed Mean Method** :-  $\bar{x} = A + \frac{\sum f_i d_i}{\sum f_i}$   
Where  $d = x_i - A$ ,       $A =$  Assumed Mean
3. **Step Deviation Method** :-  $\bar{x} = A + \frac{\sum f_i u_i}{\sum f_i} \times h$   
Where  $u = \frac{x_i - a}{h}$   
&  $A =$  Assumed Mean,       $h =$  Class size
- ~~~~~

**MEDIAN :-**

**For Discrete Data :-**

(i) If N is odd then  $(\frac{N+1}{2})^{\text{th}}$  term is the median.

(ii) If N is even then median = Average of  $(\frac{N}{2})^{\text{th}}$  &  $(\frac{N}{2} + 1)^{\text{th}}$  term

**For Group Data :-**

$$\text{Median} = l + \frac{\frac{N}{2} - C}{f} \times h$$

Where l = lower limit of median class

c = Cumulative frequency of class preceding median class

h = Class size of median class

f = Frequency of median class,

$N = \sum f$

| C. I. | f   | C. f |
|-------|-----|------|
| (l)   | (f) | (C)  |
| N     |     |      |

← Median Class

**MODE :-**

The highest occurring element in a raw data is called mean.

**For Group Distribution :-**

$$\text{Mode} = l + \frac{f_1 - f_0}{2f_1 - f_0 - f_2} \times h$$

Where l = Lower Limit of modal class

$f_0$  = Frequency of modal class

$f_1$  = Frequency of class preceding modal class

$f_2$  = Frequency of class succeeding modal class

h = Class size of modal class

**PROBABILITY :-**

(i) Outcomes when one coin is tossed = {H, T}

(ii) Outcomes when two coins are tossed.

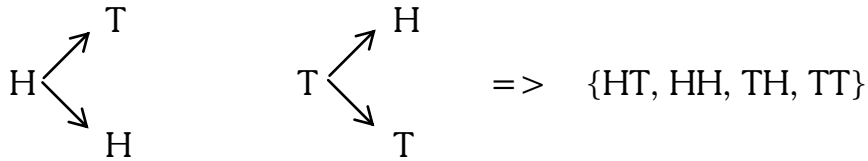

(iii) Outcomes when three coins are tossed.

{HHH, HHT, HTH, THH, TTH, THT, HTT, TTT}

(iv) A dice if tossed once {1, 2, 3, 4, 5, 6}

(v) A dice if tossed twice

- (1, 1) (1, 2) (1, 3) (1, 4) (1, 5) (1, 6)
- (2, 1) (2, 2) (2, 3) (2, 4) (2, 5) (2, 6)
- (3, 1) (3, 2) (3, 3) (3, 4) (3, 5) (3, 6)
- (4, 1) (4, 2) (4, 3) (4, 4) (4, 5) (4, 6)
- (5, 1) (5, 2) (5, 3) (5, 4) (5, 5) (5, 6)
- (6, 1) (6, 2) (6, 3) (6, 4) (6, 5) (6, 6)

(vi) Playing Cards

Total = 52

|     | Suits   | Colour | Total Cards | Ace | Numbers       | Jack | Queen | King |
|-----|---------|--------|-------------|-----|---------------|------|-------|------|
| (a) | Spade   | Black  | 13          | 1   | 2, 3 _ _ _ 10 | J    | Q     | K    |
| (b) | Club    | Black  | 13          | 1   | 2, 3 _ _ _ 10 | J    | Q     | K    |
| (c) | Heart   | Red    | 13          | 1   | 2, 3 _ _ _ 10 | J    | Q     | K    |
| (d) | Diamond | Red    | 13          | 1   | 2, 3 _ _ _ 10 | J    | Q     | K    |
|     | Total   |        | 52          | 4   |               | 4    | 4     | 4    |

Face Cards :- Jacks + Queens + King = 4 + 4 + 4 = 12 Cards



- : SOME IMPORTANT CONVERSIONS :-



Any conversion from up wards to down wards multiply in the multiple of 10 for every step respectively and down wards to up wards, divide in the multiple of 10.

1 hectare = 10000m<sup>2</sup>

1 are = 100 m<sup>2</sup>

1 litre = 1000 cm<sup>3</sup>

1 kilolitre = 1 m<sup>3</sup> = 1000 litres

m/sec to km/hr => Multiply by  $\frac{18}{5} \left( \frac{60 \times 60}{1000} \right)$

km/hr to m/sec => Multiply by  $\frac{5}{18} \left( \frac{1000}{60 \times 60} \right)$

