

Directorate of Education

Govt. of NCT of Delhi
Value based support Material for the
session 2012-13

Subject – Mathematics
Class – IX

Under the guidance of
Dr. Sunita S. Kaushik
Addl. DE (School/Exam)

Coordination by :
Shakuntla Mahajan
(Principal)
GGSS School, Sri Niwaspuri, New Delhi 110065

PREPARED BY :

1. Mrs. Savita Vij (Govt. Co-Ed S.S. School No. 1, Lajpat Nagar)
2. Mrs. Alka Gupta (GGSS School, Sri Niwaspuri)
3. Mrs. Suman Sharma (GGSS School, Sri Niwaspuri)
4. Mrs. Shradha Sharma (Govt. Co-Ed Sec. School, Jangpura)
5. Mrs. Babita Khanna (Govt. Co-Ed Sec. School, Jangpura)

LINEAR EQUATION

1. In a village primary school enrolment of girls has doubled this year as compared to last year. Considering this year's enrolment as 'y' and previous year's enrollment as x :
 - (a) Form a linear equation for this information.
 - (b) If previous year's enrolment was 35 find this year's enrollment.
 - (c) What is the value depicted here ?
2. On her birthday Sonia distributed chocolates in an orphanage. She gave 5 chocolates to each child and 20 chocolates to adults. Taking number of children as x and total chocolates distributed as y.
 - (a) Form a linear equation.
 - (b) If she distributed 145 chocolates how many children are there in the orphanage ?
 - (c) Explain the value depicted here by Sonia.
3. In a housing society people decided to do Rainwater harvesting. Rainwater is collected in the underground tank at the rate of $30 \text{ cm}^3/\text{sec}$. Taking volume of water collected in x sec as y cm^3 .
 - (a) Form a linear equation.
 - (b) Write it in standard form as $ax+by+c=0$.
 - (c) Which value is promoted by the members of this society ?
4. A man hires an auto rickshaw to cover a certain distance. The fare is Rs. 10 for first km and Rs. 7 for subsequent kilometers. Taking total distance covered as x km and total fare as y :
 - (a) Write a linear equation for this.
 - (b) The man covers a distance of 16 km and gave Rs. 120 to the auto driver. Auto driver said "It is not the correct amount" and returned him the balance. Find the correct amount paid back by the autodriver.
 - (c) Which value is depicted here by the autodriver ?

5. In a “Cleanliness drive” residents of certain locality joined together to clean neighbourhood area. Participation of children was 20 more than that by adults. Taking x as number of adults and y as number of children.
- (a) Form a linear equation.
 (b) What values are depicted here ?
6. Rehman and Prakash together contributed Rs. 500 towards Prime Minister Relief fund.
- (a) Write the linear equation for this.
 (b) Write the values involved in it.
7. Draw the graph of the linear equation $2(x+1)=3(y-1)-4$ and check whether point $(-3, +1)$ lies on the line ?
 Which value is depicted here ?
8. In a class, teacher asked about the equ. of line passing through the origin with options as :
 $y+x=1$, $x+3y=2$, $x+y=0$
 Rehana answered it correctly as $x+y=0$.
 Choose the correct value :
 (a) Honesty (b) Equality (c) Truthfulness (d) Sincerity
- 9.

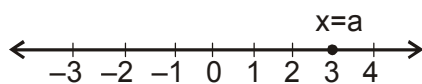

Fig. (i)

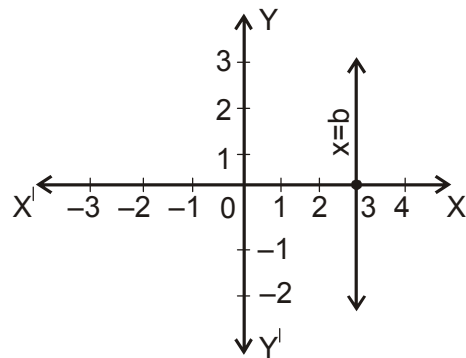

Fig. (ii)

- (a) In the above fig. (i) & (ii) find the values of a & b.
- (b) Is $a=b$? Justify your answer.
- (c) What is the value depicted here ?
10. (a) Every six months price of petrol increases at the rate of Rs. 4 per litre. Taking price of petrol in Dec. 2011 as 'x' and present price of petrol as 'y' form a linear equation showing amount spent on petrol in Dec. 2012.
- (b) Due to continuous rise in the petrol price people are shifting towards CNG in place of petrol whose price increases at a rate of Rs. 3 per litre in a year. Form a linear equation taking price of CNG in Dec. 2011 as 'a' and in Dec. 2012, as 'b'.
- (c) Which fuel will you prefer and why ?
- (d) Which value is depicted by using CNG over petrol ?

ANSWERS

1. (a) $y=2x$
- (b) $y=2 \times 35=70$
- (c) Freedom, Gender equality.
2. (a) $y=5x+20$
- (b) $145=5x+20$
 $\Rightarrow 125=5x$
 $\Rightarrow x=25$
- (c) Happiness, Helpfulness
3. (a) $y=30x$
- (b) $30x-y+0=0$
- (c) Environmental protection, Co-operation.

4. (a) $y=10+7(x-1)$
 $=10+7x-7$
 $y=7x+3$
(b) $y=7 \times 16+3$
 $=112+3=115$ Rs. Amt. Paid back = $120-115 = 5$ Rs.
(c) Honesty, Truthfulness.
5. (a) $y=x+20$
(b) Co-operation, Happiness, Sincerity, Environmental protection.
6. (a) $x+y=500$
(b) Co-operation, Helpfulness
7. (a) Equation
 $2(x+1)=3(y-1)-4$
 $\Rightarrow 2x+2=3y-3-4$
 $\Rightarrow 2x-3y+9=0$
Point $(-3, +1)$ lies on it as
 $2 \times (-3) - 3(+1) + 9 = -6 - 3 + 9$
 $= -9 + 9 = 0 = \text{RHS.}$
(b) Curiosity, Truthfulness, Scientific temper.
8. (c) Truthfulness
9. (a) $a=3, b=3$
(b) Yes
(c) Scientific temper, Truthfulness, Knowledge.
10. (a) $y=x+8$
(b) $b=a+3$
(c) CNG, because CNG is cheaper than petrol.
(d) Environmental protection.

QUADRILATERALS

1.

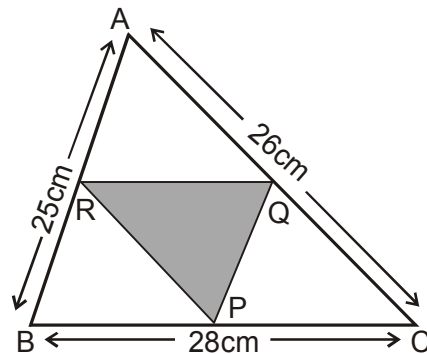

There is a visit in a school by Directorate of Education. Girls are asked to prepare Rangoli in triangular shape. Dimensions of $\triangle ABC$ are 26 cm, 28 cm, 25 cm. Garland is to be placed along the side of $\triangle PQR$ which is formed by joining midpoints of sides of $\triangle ABC$.

- (a) Find the length of garland.
 - (b) What values are depicted here ?
2. A class teacher gave students coloured papers in the shape of quadrilateral. She asked them to make parallelogram from it using paper folding.
- (a) How can a parallelogram be formed by using paper folding ?
 - (b) Prove that it is a parallelogram.
 - (c) What values are depicted here ?
3. ABCD is a rhombus where $\angle ADC = 120^\circ$. There are two fire stations at C and D and fire is reported at O.

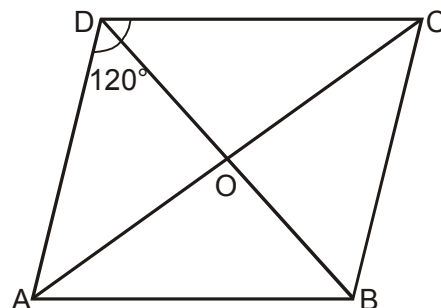

[6]

- (a) Which fire station team can reach early and why ?
- (b) Which value is depicted here ?
4. Sohan wants to show gratitude towards his teacher by giving her a card made by him. He has three pieces of trapezium pasted one above the other as shown in the fig. These pieces are arranged in a way that $AB \parallel HC \parallel GD \parallel FE$. Also $BC=CD=DE$ and $GF=6$ cm. He wants to decorate the card by putting up a coloured tape on non parallel sides of trapezium.

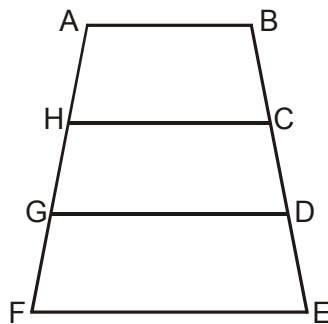

- (a) Find the total length of coloured tape required if $DE = 4$ cm.
- (b) Which value is depicted by the student ?
5. A farmer has a field in the form of a parallelogram ABCD. One of his cow is suffering from some disease. To take good care of her, he tied the cow at one corner of the field. The corner angle of the field is 65° .

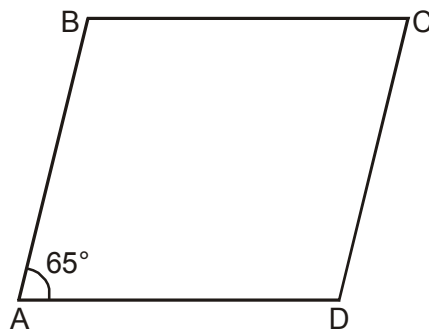

- (a) Find all the other three angles of the field.
- (b) Explain the values depicted here.

6. A chocolate is in the form of a quadrilateral with sides 6 cm, 10 cm, 5 cm, 5 cm is cut into two parts along one of its diagonals by a lady. Part I is given to her maid and part II is equally divided among her driver and maali.

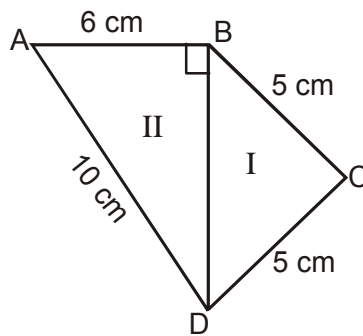

- (a) Is this distribution fair ? Justify it.
 (b) What value is depicted here ?
7. While analysing properties of quadrilateral a child says that all angles of a quadrilateral can not be obtuse.
- (a) Justify his answer.
 (b) What value is depicted in this activity ?
8. During Maths Lab Activity each student was given four broom sticks of lengths 8 cm, 8 cm, 5 cm, 5 cm to make different types of quadrilaterals.
- (a) How many quadrilaterals can be formed using these sticks.
 (b) Name the types of quadrilaterals formed.
 (c) While doing this activity which value is depicted ?

9. In a trapezium ABCD $DC \parallel AB$ and $\angle A = \angle B = 45^\circ$. teacher asked the student to find $\angle D$. Naresh

answered it as 135°

- (a) Is the answer correct ? Justify it.
 (b) Which value is depicted here ?

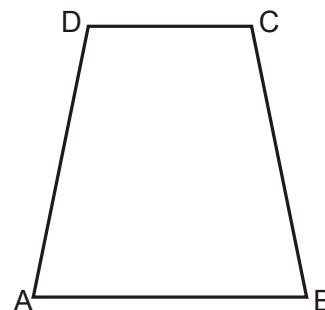

- 10- While discussing the properties of a parallelogram teacher asked about the relation between two angles x and y of a parallelogram as shown in the fig. Teacher gave them three options as :

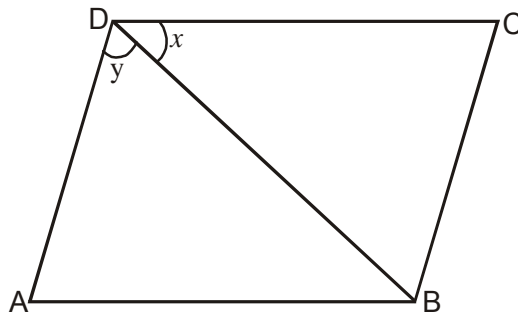

- (i) $x > y$ (ii) $x < y$ (iii) $x = y$

Beena gave the answer as $x < y$

- (a) Is this the correct answer ?
 (b) Justify the answer with suitable logic.
 (c) What is the value depicted in this ?

QUADRILATERALS

ANSWERS

1. (a) $RQ \parallel BC$ and $RQ = \frac{1}{2}BC$
 (Mid pt. theorem)
 $\Rightarrow RQ = 14$ cm
 $QP = 12.5$ cm
 $PR = 13$ cm
 Perimetre = $14+12.5+13$
 $= 39.5$ cm
 (b) Beauty, happiness, co-operation

2.

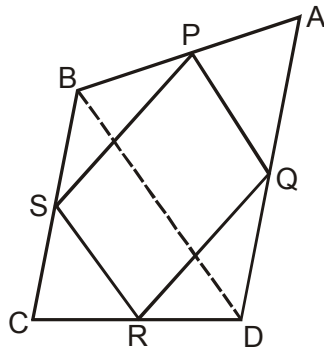

(a) By joining mid pts. of sides of a quadrilateral.

(b) In $\triangle ABD$

P & Q are mid point of AB and AD

$$\therefore PQ \parallel BD \text{ \& } PQ = \frac{1}{2}BD \text{(i) (Mid point theorem)}$$

$$\text{similarly, } RS \parallel BD \text{ \& } RS = \frac{1}{2}BD \text{(ii)}$$

from (i) & (ii) PQRS is a parallelogram

(c) Curiosity, Happiness, Scientific Temper

3. (a) D will send the team early $\angle ODC = 60^\circ$ & $\angle OCD = 30^\circ$

$$\Rightarrow OC > OD \text{ (side opp. to larger angle is longer)}$$

(b) Serving the people with honesty

4. (a) $AB \parallel HC \parallel GD \parallel FE$ and $BC = CD = DE$

$$\Rightarrow AH = HG = GF$$

(given three parallel lines making equal intercepts on any transversal then they will make equal intercepts on other transversal also)

$$\therefore AF + FE = 18 + 12 = 30 \text{ cm}$$

(b) Happiness, beauty, knowledge

5. (a) $\angle A = \angle C = 65^\circ$
 $\angle B = 180^\circ - 65^\circ$
 $= 115^\circ = \angle D$
- (b) Helpfulness, caring for every one
6. (a) Distribution is fair
- (b) $BD = \sqrt{AD^2 - AB^2} = \sqrt{100 - 36} = \sqrt{64}$
 $BD = 8 \text{ cm}$
- $\text{ar (ABD)} = \frac{1}{2} \times 6 \times 8$
 $= 24 \text{ cm}^2$
- ar (BCD)
- $S = \frac{a + b + c}{2} = \frac{5 + 5 + 8}{2} = 9 \text{ cm}$
- $\text{area} = \sqrt{9 \times (9 - 5) \times (9 - 5) \times (9 - 8)}$
 $= \sqrt{9 \times 4 \times 4 \times 1}$
 $= 12 \text{ cm}^2$
- (c) Helpfulness, Caring
7. (a) If $\angle A = 91^\circ$, $\angle B = 91^\circ$, $\angle C = 91^\circ$ then $\angle D < 90^\circ$
as $\angle A + \angle B + \angle C + \angle D = 360^\circ$
- (b) Scientific temper, knowledge
8. (a) Three type of quadrilaterals can be formed
- (b) Rectangle, parallelogram, kite
- (c) Scientific temper, curiosity

9. (a) $DC \parallel AB$
 $\Rightarrow \angle A + \angle D = 180^\circ$
 $\Rightarrow \angle D = 180^\circ - 45^\circ = 135^\circ$
- (b) Scientific temper, truth value
10. (a) Yes
- (b) $\angle ADB = \angle DBC = y$ (alternate int. angles)
since $BC < CD$ (angle opp. to smaller side is smaller)
 $\therefore x < y$
- (c) Truth value

AREAS OF PARALLELOGRAMS AND TRIANGLES

1. A craft mela is organised by Welfare Association to promote the art and culture of tribal people. The pandal is to be decorated by using string of bulbs all around the field. There are two options either to arrange it in a rectangular field ABEF or parallelogram ABCD with equal area.

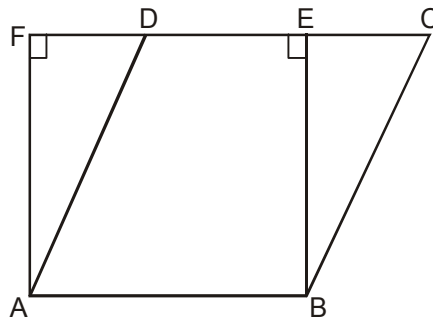

- (a) What shape of the field should be chosen to minimise the expense of bulb and why ?
 - (b) Which values are depicted here ?
2. A plot is in the form of a parallelogram ABCD. Owner of this plot wants to build OLD AGE HOME, DISPENSARY, PARK and HEALTH CENTRE for elderly people as shown in the fig. P is a point on the diagonal BD.

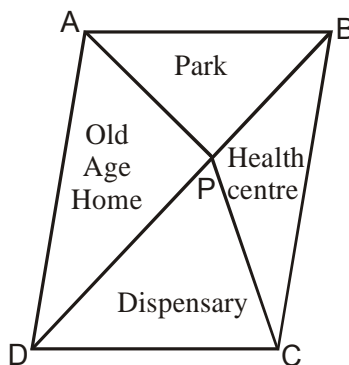

- (a) Prove that area allotted to old age home and dispensary is same.
- (b) Which values are depicted here ?

3. There was a deserted land near a colony where people used to throw garbage. Colony people united to develop a pond in triangular shape as shown in the fig. The land is in the shape of ||gm ABCD. In rest of the portion medicinal plants were grown. If area of parallelogram ABCD is 200 m^2 .

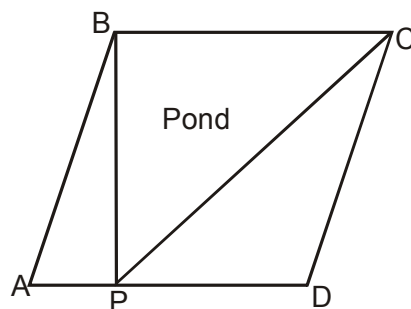

- (a) Calculate the area where medicinal plants were grown.
 (b) Which value is depicted here ?
4. For 'Sarva Shiksha Abhiyan' a rally was organised by a school. Students were given triangular cardboard pieces to write slogans. They divided the triangular shape into three equal parts by drawing medians as shown in fig.

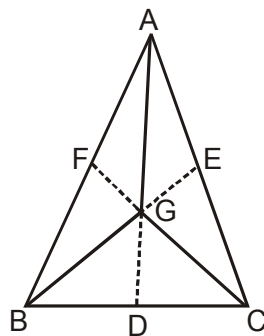

- (a) Prove that area (AGC) = area (AGB)
 = area (BGC)

$$= \frac{1}{3} \text{ area (ABC)}$$
- (b) Which values are inculcated through this activity ?

[14]

5. A farmer has a square plot of land where he wants to grow five different crops at a time. On half of the area in the middle he wants to grow wheat but in rest four equal triangular parts he wants to grow different crops.
- (a) Explain by diagram how he can divide the area to fulfill his purpose.
- (b) By using this crop pattern which values are depicted by the farmer?
6. There is a plot in a village in the shape of a quadrilateral ABCD. Sarpanch wants to get floor cemented so as to use it for social gatherings and panchayat meetings. Later due to construction of park in the neighbourhood for children they decided to change the shape to triangle ABP.

If $AC \parallel DP$

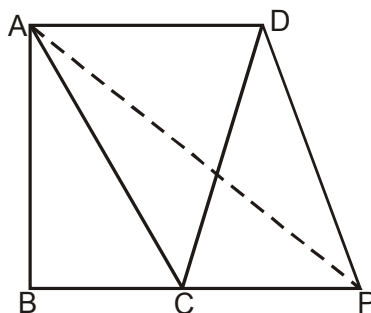

- (a) Prove that $\text{ar}(\text{quad. } ABCD) = \text{ar}(\Delta ABP)$
- (b) What are the values depicted in this activity ?
7. On National Integration day a poster is to be made by class IX students of a school. This poster is in the shape of a parallelogram. All religions should be given equal triangular space to display their teachings.
- (a) How will they divide a parallelogram into four triangles equal in area ? Justify it.
- (b) What are the values depicted here ?
8. In a class, teacher gave two identical cardboard pieces which are in the shape of a parallelogram to two groups. First group was asked to find

area of parallelogram using AB as base. Then another group was asked to find height (h) of the parallelogram with AD as base.

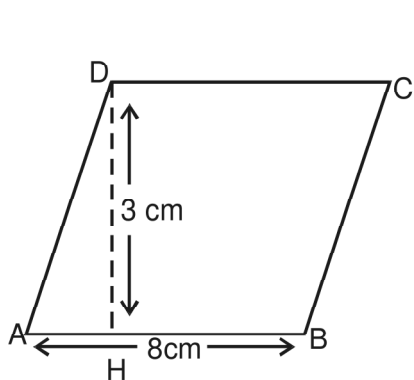

Group (I)

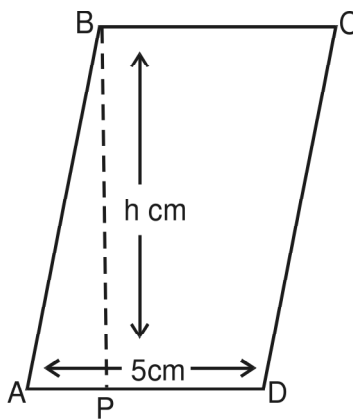

Group (II)

- (a) How will they find value of h ?
- (b) What are the values involved here ?

9. In a class, teacher asks the students to cut a figure from a given parallelogram which has area equal to half the area of parallelogram ABCD.

Sunita joins the mid points of opposite sides of parallelogram as shown in the fig.

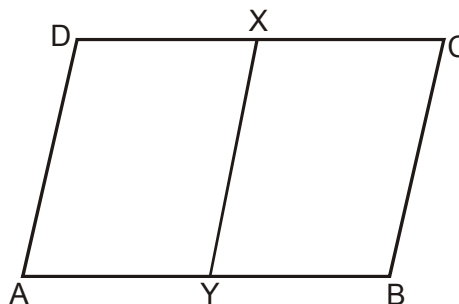

Where as Rohan draws a triangle on the same base as shown in fig.

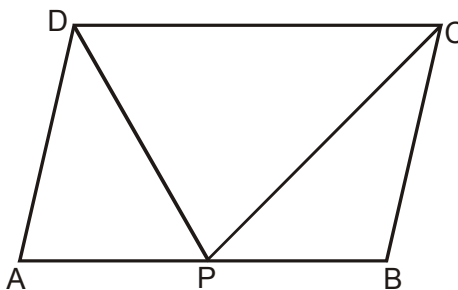

- (a) State whether two answers are correct. Justify.
- (b) What values are depicted from this activity ?

10. In a rhombus ABCD, AC = 8 cm, then AO = 4 cm.

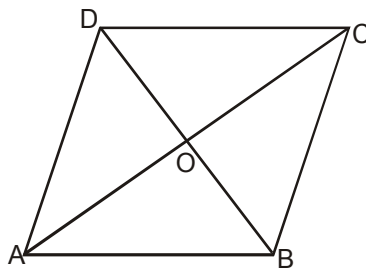

The statement shows

- (a) Truth value
- (b) Social value
- (c) Environment value
- (d) Cooperation

Justify your answer.

ANSWER

- 1. (a) Rectangle as
Perimeter of rectangle < Perimeter of parallelogram
- (b) Co-operation, helpfulness

- 2. (a) Join AC
Diagonals AC & BD of a ||gm ABCD bisect at O.
⇒ AO = OC and BO = OD

In ΔAPC, PO is median (∵ Median divides a triangle in two triangles equal in area)

∴ ar (APO) = ar (CPO) (i)

In ΔADC,

DO is median

∴ ar (ADO) = ar(DCO) (ii)

Adding (i) & (ii)

ar (APO) + ar (ADO) = ar (CPO) + ar (DCO)

⇒ ar (ADP) = ar (DPC)

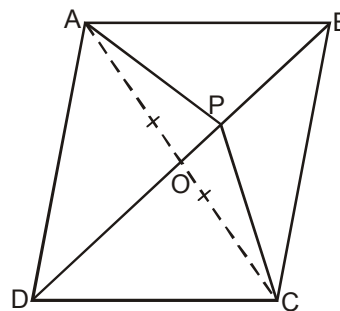

- (b) Helpfulness, happiness, cooperation

3. (a) 100 sq. cm.
 (b) Environmental protection, cooperation

4. (a) In ΔABC , AD is median
 $\therefore \text{ar}(\Delta ABD) = \text{ar}(\Delta ADC)$ _____ (i)
 also $\text{ar}(\Delta GBD) = \text{ar}(\Delta GDC)$ _____ (ii)
 subtracting (ii) from (i)
 $\text{ar}(\Delta AGB) = \text{ar}(\Delta AGC)$
 similarly
 $\text{ar}(\Delta AGB) = \text{ar}(\Delta AGC) = \text{ar}(\Delta GBC)$

- (b) Cooperation, sincerity

5. (a)

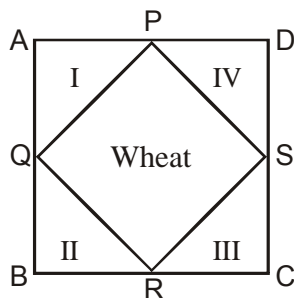

joining midpoints of sides

- (b) Increases fertility of soil, environmental protection, happiness.
 6. (a) Since $AC \parallel DP$

$$\text{ar}(\Delta ADC) = \text{ar}(\Delta APC) \dots\dots\dots(i)$$

(\because triangles on the same base AC and between same parallels AC & DP are equal in area)

Adding $\text{ar}(\Delta ABC)$ to both sides of (i)

$$\text{ar}(\Delta ADC) + \text{ar}(\Delta ABC) = \text{ar}(\Delta APC) + \text{ar}(\Delta ABC)$$

$$\Rightarrow \text{ar}(\Delta ABCD) = \text{ar}(\Delta ABP)$$

- (b) Environmental protection, respecting others views

7. (a) Diagonals of a || gm divides it into four triangles of equal area.
(b) Unity of nation, co-operation, fraternity
8. (a) Area of || gm ABCD
 $AB \times DH = AD \times BP$
 $8 \times 3 = 5 \times h$
 $\frac{8 \times 3}{5} = h$
 $\frac{24}{5} = h$
 $h = 4.8 \text{ cm.}$
- (b) Scientific temper, cooperation
9. (a) Both are giving correct answer.
(b) Scientific temper, curiosity, co-operation.
10. (a) Truth value

CIRCLES

1. Three friends ordered 3 pizzas of same size for them. Just then two more friends joined them. They decided to share 3 pizzas among all 5 of them.
 - (a) Find the area of the share of pizza each child gets if the radius of each pizza is 7 cm.
 - (b) Which values of children are depicted here ?
2. During ‘Van Mahotsav’ celebration in a school a circular plot in the corner of the school was chosen. Five groups of students were selected to plant trees in each part as shown in the fig.

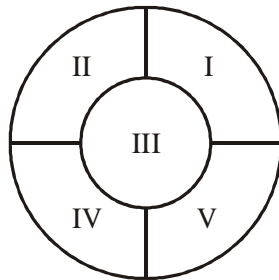

- (a) Which group gets the maximum area to develop and by how much, if the two radii are 210 cm & 105 cm respectively.
 - (b) What values can be inculcated in students through this activity ?
3. The Indian hockey federation organized a friendly hockey match between India and Pakistan on a circular ground. The sale proceeds of this match shall be donated to an orphanage. A rectangular turf is spread on the ground as shown in the figure.

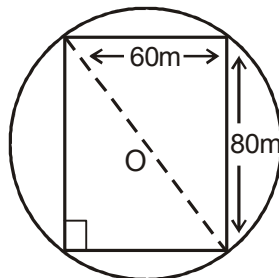

- (a) Find the radius of the stadium.
- (b) Which social values is depicted here ?
- (c) How does donation to charitable organisations help in the development of society ?
4. A school decided to paint its inner boundary wall. They planned to write quotations and social messages for the children on the circular areas of radius 40 cm each on the wall along a straight line.

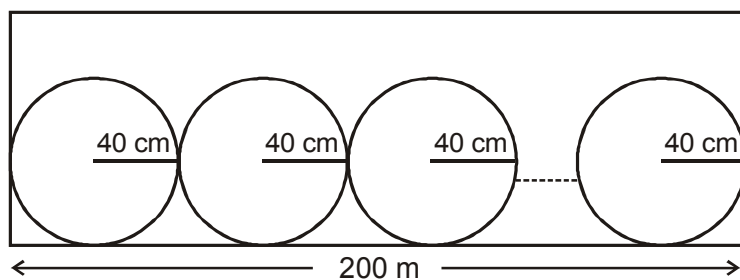

If the boundary wall is 200 m long

- (a) How many circles can be drawn ?
- (b) What values are inculcated in the students by this activity ?
5. A group of 66 students went for a picnic. They halted at a park for their lunch. They made a big circle and each child was 50 cm away from the other child along the circle.

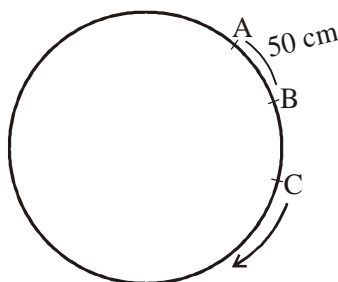

- (a) Find the radius of the circle they formed.
- (b) What values do these students possess ?
6. An amusement fair was organised in a circular park for the children of slum clusters. Free food was supplied to them at 4 stalls situated at

A, B, C and D as shown in the figure.

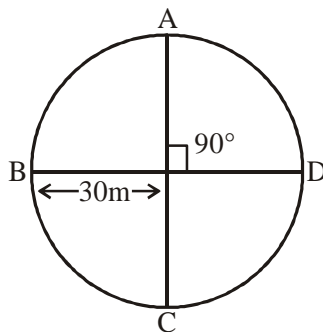

- (a) Find the distance between any two adjacent food stalls if the radius of the park is 30 m.
- (b) Are such activities helpful for society ? What are the other social issues for which such compaigns are required ?
7. Children of a colony decided to assist and help an old couple of the colony in developing their vacant plot as flower bed as shown here. The radii of the two circles is 245 cm and 210 cm.
- (a) Find the area of the grass cover.
- (b) Which values are depicted by the children?
8. 3 STD booths situated at A, B and C in the fig. are operated by handicapped persons. These three booths are equidistant from each other as shown in the figure.

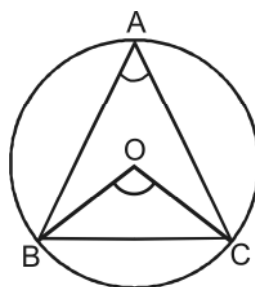
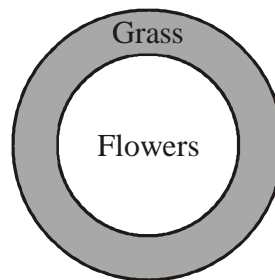

- (a) Find $\angle BOC$
- (b) Do you think employment provided to handicapped persons is important for the development of a society ? Justify your answer.

ANSWERS

1. (a) 92.4 cm^2 (b) co-operation
2. (a) Group III, 8662.5 sq. cm
(b) Environmental protection, beauty
3. (a) 50 m (b) Helpfulness, co-operation
(c) This money is utilized for welfare of orphans.
4. (a) 250 (b) Beauty
5. (a) 5.25 m (b) Co-operation, happiness
6. (a) $30\sqrt{2} \text{ m}$
(b) Yes, for the inmates of old age home, orphanages, handicapped children etc.
7. (a) 50050 sq. cm (b) Helpfulness
8. (a) 120° (b) Yes
9. (a) Yes (b) 55° (c) Truth, scientific temper
10. $\angle ACD = 90^\circ$
 $\angle BAD + \angle BCD = 180^\circ$ (opposites angles of a cyclic quadrilateral)
 $y+x+90 = 180$
 $\therefore x + y = 90^\circ$
Truthfulness, knowledge

CONSTRUCTION

1. Delhi traffic police wants to make a traffic signal board of the shape of an equilateral triangle of side 5 m to make the people aware of the traffic rules. Construct the above traffic signal board by taking each side as 5 cm (instead of m). What value is depicted here ?
2. Ram Lal has a triangular piece of land ABC in which $\angle B = 30^\circ$, $\angle C = 90^\circ$, $AB+BC+CA = 11$ m. He donated this to a vridhashram. Construct a triangle using above dimensions (use cm in place of m). What value represents here ?
3. Students of a school staged a rally for cleanliness campaign. They walked through the lanes AB, BC and CA which form a triangle. Construct the ΔABC in which $BC = 8$ m, $\angle B = 45^\circ$ $AB-AC = 3.5$ m. What value represents here ? (Construct the triangle using cm in place of m)
4. A co-operative house adopted a triangular park ΔPQR to maintain its greenary of dimensions $QR = 7$ m, $\angle Q = 75^\circ$ and $PQ + PR = 13$ m, Make a ΔPQR using cm instead of m. What value represents here ?
5. The villagers of a village wish to make a pool to drink water for animals. They constructed it in the shape of a triangle. The dimensions of the pool are 5m and 12m and the angle between them is 90° . Construct it by taking as cm instead of m. What value represents here?
6. Mohan and Sohan constructed a right angle. Choose the correct option. What idea is depicted here?

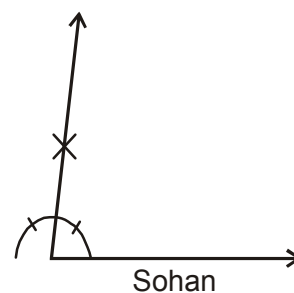
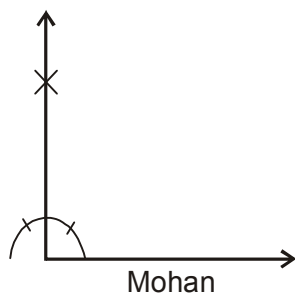

[25]

ANSWERS

1. (a) Do correct construction
(b) To make the people aware of traffic rules for safety measures.
2. (a) Do correct construction
(b) Habit of donation
3. (a) Do correct construction
(b) To make the environment clean.
4. (a) Do correct construction
(b) (i) To make the environment clean.
(ii) Community services
5. (a) Do correct construction
(b) Social work
6. (a) Mohan is correct
(b) Truth value
7. (a) Do correct construction
(b) Habit of donation, social work
8. (a) $60 + \frac{1}{4} \times 60$
(b) Truth value
9. (a) Do correct construction
(b) Community services, Social services
10. (a) Do correct construction
(b) Community services

5. Ashwani a factory owner wants to thank all his workers by gifting a decorated spherical ball. The diameter of the sphere is $(2a+5)$ cm. Each ball is to be packed in a right circular cylindrical box which just encloses a sphere as shown in the figure.

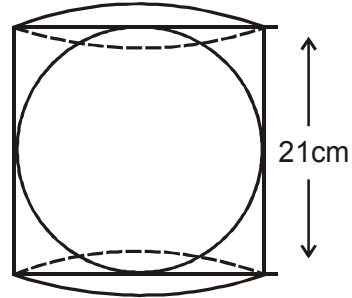

If the height of the cylinder is 21cm then

- (a) What is the value of 'a' ?
 - (b) What is the curved surface area of a sphere ?
 - (c) Which value is shown by Ashwani ?
6. A residential colony has a population of 5400 and 60 litres of water is required per person per day. For the effective utilization of rain water, a group of people decided to do WATER HARVESTING. They constructed a water reservoir measuring $48\text{m} \times 27\text{m} \times 25\text{m}$ to collect the rain water.
- (a) For how many days the water of this tank is sufficient if during rain the height of water level is 5m.
 - (b) Which value is shown by the group of people ?
7. The patients in a hospital are given soup daily in a cylindrical bowl of diameter 7cm. On a particular day, the girls of KANYA MAHAVIDYALAYA decided to cook the soup for the patients. If they fill the bowl with soup to a height of 5cm then how much soup is to be cooked for 300 patients ? Which value is depicted by the girls ?
8. The resident of society decided to paint the hall of cancer detective centre in their premises. If the floor of the cuboidal hall has a perimeter equal to 250 m and height 6m then
- (a) Find the cost of painting its four walls (including doors etc) at the rate of Rs. 8 per m^2 .
 - (b) What is the amount contributed by 50 people ?
 - (c) Which value is depicted by the residents ?

9. Sunidhi is curious to find out the relationship between the diameter of the moon and the earth. From the data available, it is known that the volume of earth is 64 times the volume of the moon. She concluded that the diameter of the moon is $\frac{1}{4}$ of the diameter of the earth.
- (a) Justify her statement by proving it.
- (b) Which value is depicted by Sunidhi by conducting the experiment?
10. There are 100 students in a blind school. Mr. and Mrs. Ramesh wished to serve them milk. They have two options for serving the milk.
- Option A – A hemispherical bowl with radius 10.5 cm made up of ecofriendly material.
- Option B – A hemispherical bowl with radius 7 cm made up of plastic.
- (a) How many litres of milk is required if option A is taken.
- (b) Find the total quantity of milk (in litres) if option B is taken.
- (c) Mr. and Mrs. Ramesh opted for option A which value is shown by them.

ANSWERS

1. volume of cone = $\frac{1}{3}\pi r^2 h$ (i)

also $l^2 = r^2 + h^2$

$r^2 = l^2 - h^2$ (ii)

substituting (ii) in (i) we get,

$$v = \frac{1}{3}\pi(l^2 - h^2)h$$

$$= \frac{1}{3}l^2h - \frac{1}{3}\pi h^3$$

so ans. is (a)

2. (a) $r = 4.2 \text{ cm.}, h = 11.2 \text{ cm}$

S.A. of cylindrical vase = CSA + area of base

$$= 2\pi rh + \pi r^2$$

$$= 2\pi \times 4.2 \times 11.2 + \pi(4.2)^2$$

$$= 4.2 \pi (22.4 + 4.2)$$

$$= 4.2 \times \frac{22}{7} \times 26.6$$

$$= 351.12 \text{ cm}^2$$

$$\text{SA of 50 cylinder} = 50 \times 351.12$$

$$= 17556 \text{ cm}^2$$

$$\text{Total cost} = 17556 \times \frac{20}{100}$$

$$= \text{Rs. } 3511.20$$

(b) Social value / co-operation / caring for old people.

3. (a) CSA of conical tent = $3.14 \times 3 \times \sqrt{3^2 + 4^2}$

$$= 47.1 \text{ m}^2$$

$$\text{Area of trapaulin used} = (47.1 + 10\% \text{ of } 47.1) \text{ m}^2$$

$$= 51.81 \text{ m}^2$$

$$\text{Required length of trapaulin} = \frac{51.81}{1.5} \text{ m}$$

$$= 34.54 \text{ m}$$

(b) Social value, helpfulness

4. (a) $r = 20 \text{ cm} = 0.2 \text{ m}$

$$h = 1 \text{ m}$$

$$l^2 = h^2 + r^2 = 1 + .04 = 1.04$$

$$l = \sqrt{1.04} = 1.02 \text{ m}$$

$$\begin{aligned} \text{curved S.A of 50 cones} &= (50 \times 3.14 \times 0.2 \times 1.02) \text{ m}^2 \\ &= 32.028 \text{ m}^2 \end{aligned}$$

$$\begin{aligned} \text{Total cost of painting} &= \text{Rs. } 12 \times 32.028 \\ &= \text{Rs. } 384.34 \end{aligned}$$

(b) Social value, environmental protection.

5. (a) diameter of sphere = height of cylinder

$$2a + 5 = 21$$

$$2a = 21 - 5 = 16$$

$$a = 8$$

(b) CSA of sphere = $4\pi r^2$

$$= 4 \times \frac{22}{7} \times \frac{21}{2} \times \frac{21}{2}$$

$$= 1386 \text{ cm}^2$$

(c) Social justice, caring

6. (a) Total volume of water = $(48 \times 27 \times 5) \text{ m}^3$

$$= 48 \times 27 \times 5 \times 1000 \text{ litres}$$

Requirement of water for one day = 5400×60 litres

$$\text{No. of days} = \frac{48 \times 27 \times 5 \times 1000}{5400 \times 60}$$

$$= 20 \text{ days}$$

(b) environmental value, co-operation

7. (a) Volume of the cylinder = $\pi r^2 h$

$$= \pi \times \left(\frac{7}{2}\right)^2 \times 5$$

$$= \frac{22}{2} \times \frac{7}{2} \times \frac{7}{2} \times 5$$

$$= \frac{385}{2} \text{ cm}^3$$

[32]

$$\begin{aligned} \text{volume for 300 patients} &= \frac{385}{2} \times 300 \\ &= 57750 \text{ cm}^3 \\ &= 57.750 \text{ litres} \end{aligned}$$

(b) Social cohesion, happiness

8. $P = 2(1+b) = 250$
 $= 1 + b = 125$

(a) Surface area of four walls = $2h(1+b)$
 $= 6 \times 250$
 $= 1500 \text{ m}^2$

$$\begin{aligned} \text{cost} &= 8 \times 1500 \\ &= \text{Rs. } 12000 \end{aligned}$$

(b) Amount contributed = Rs. 240

(c) Social value, co-operation, social cohesion

9. (a) Volume of earth = $64 \times$ volume of moon

$$\frac{4}{3}\pi R_1^3 = 64 \times \frac{4}{3}\pi R_2^3$$

$$\Rightarrow R_1^3 = (4R_2)^3$$

$$\text{Radius of earth} = 4 \times \text{Radius of moon}$$

$$\Rightarrow \frac{1}{4} \text{Diameter of earth} = \text{Diameter of moon}$$

(b) Curiosity, spirit of enquiry, scientific temper

10. (a) $r = 10.5 \text{ cm}$

$$\text{volume of hemisphere} = \frac{2}{3}\pi r^3$$

$$\text{Total volume} = 2.42 \times 100 = 242 \text{ l}$$

$$\begin{aligned} \text{(b) volume of hemisphere} &= \frac{2}{3}\pi r^3 \\ &= \frac{2}{3} \times \frac{22}{7} \times 7 \times 7 \times 7 \\ &= 718.6 \text{ cm}^3 \\ &= 0.719 \text{ l} \end{aligned}$$

$$\text{Total volume} = 100 \times 0.719 = 71.9 \text{ l}$$

(c) Environmental value, social value

STATISTICS

1. The enrollment of a school during six consecutive years was as follows—

Year	2000	2001	2002	2003	2004	2005
Enrollment of school	1620	2060	2540	3250	3500	3710

- (a) Find the mean of the enrollment of the school for this period.
 (b) Draw a bar graph of the above data.
 (c) What value this data represent ?
2. Status of tigers in India in last 100 years is as follows—

Year	1900	1960	2002	2007
No. of Tigers	40,000	18,000	3642	1411

- (a) Make bar graph of above data.
 (b) What idea promotes here ?
3. The following table shows the interest paid by India (in thousand crore rupees) on external debts during the period 1998-99 to 2002-03.

Year	1998-99	99-2000	2000-01	2001-02	2002-03
Interest (in thousand crore rupees)	70	84	98	106	120

- (a) Draw histogram of the above data.
 (b) What conclusion will derive from above data ?

4. The following bar graph represents the budget allocation by Govt. of NCT of Delhi under Ladli scheme.

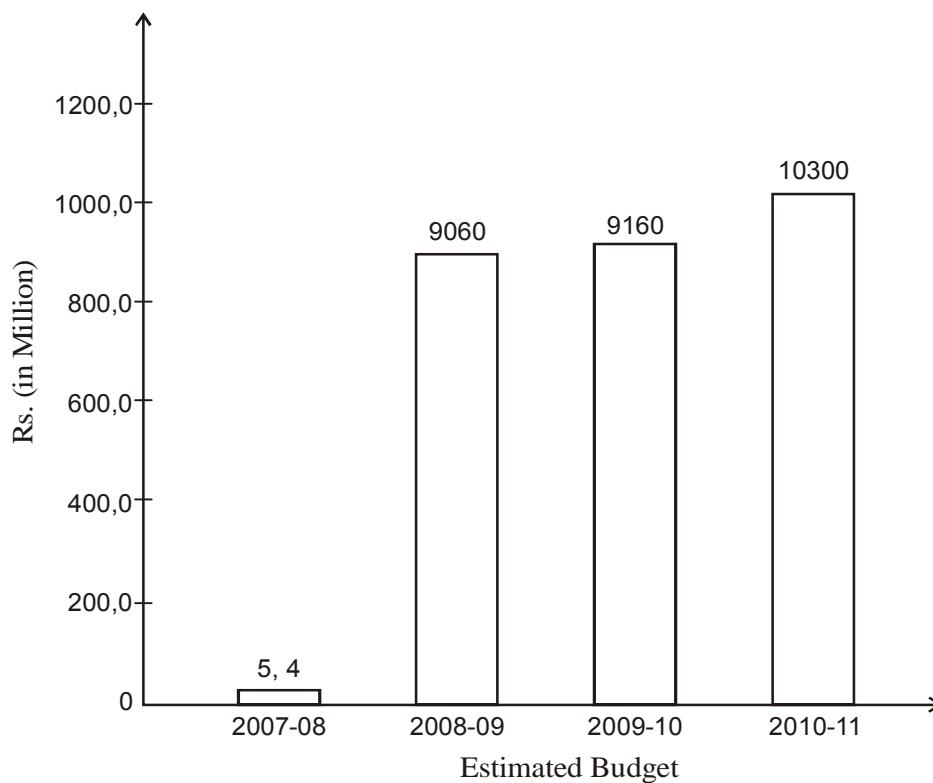

This scheme started in January 2008.

Read the above bar graph and answer the following questions.

- In which year the budget was minimum ?
 - In which year the budget was maximum ?
 - What values are depicted from the above data ?
5. 25 plants each were planted in 25 schools during Van Mahotsava.

16	20	23	10	6
10	12	7	9	15
15	22	11	13	21
17	9	4	10	12
20	15	18	18	22

- (a) Prepare a frequency distribution table of the above data using class interval 0-5 etc.
- (b) What values are represented through this activity.
6. A group of 10 students visited to a blind school. They donated Rs. 100, 120, 125, 50, 75, 100, 150, 100, 75, 85.
- (a) Find mean, mode, median of this data.
- (b) What impression will you receive through this ?
7. The following data represents the power consumption of Delhi from 2001 to 2010.

Year	2001	2005	2006	2009	2010
Power demand (in MW)	2831	3490	3626	4408	4581

- (a) Draw bar graph of above data.
- (b) What represents through the above data.
8. The following data represents the cases of deptheria and death due to deptheria—

Year	2005	2006	2007	2008	2009
No. of cases of deptheria	47	50	45	190	340
Death due to deptheria	1	0	0	30	82

- (a) In which year, the cases of deptheria were minimum ?
- (b) In which year, the deptheria death occurs ?
- (c) What value we draw from the above data ?
9. The following data represents the cases of whooping cough in India during the following years—

Year	2005-06	2006-07	2007-08	2008-09	2009-10
Cases	470	50	30	60	826

- (a) Draw frequency polygon curve of the above data.
- (b) What value represents this data ?

10. 10 people were asked about the time they spent in a week in doing social work in their community. They said 10, 7, 13, 10, 20, 15, 10, 14, 12, 16 hours resp. Find the mean, mode, median time in a week devoted by them for social work.

What value we draw from the above data ?

ANSWERS

1. (a) 2780

(b)

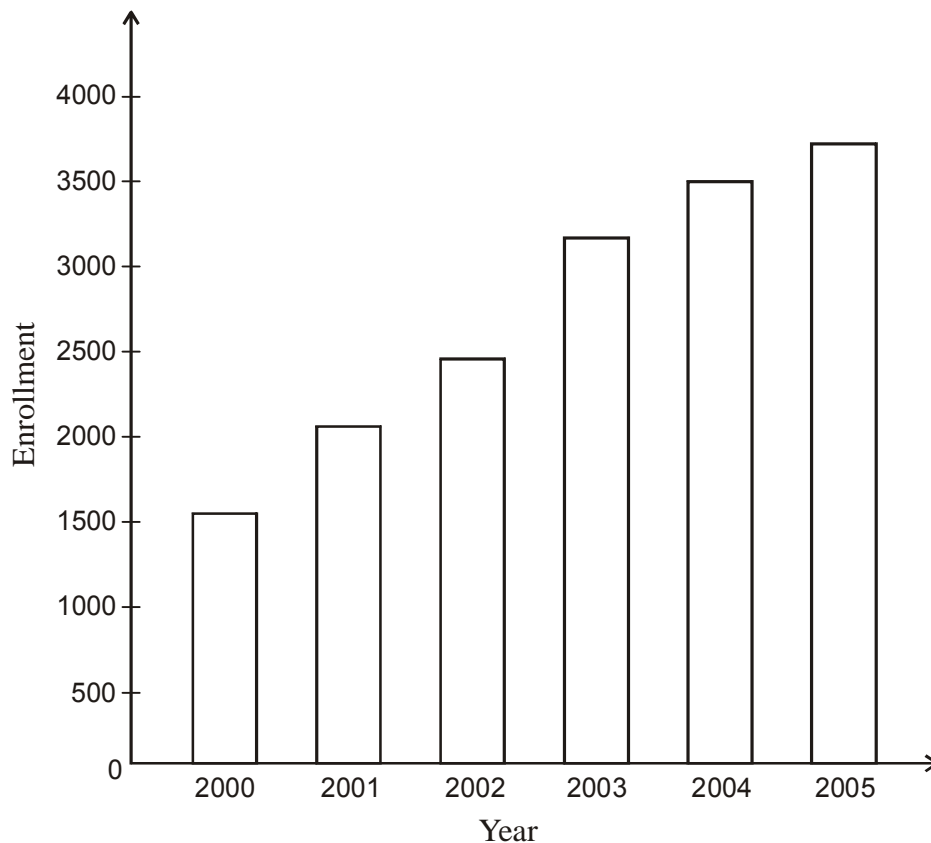

- (c) Awareness of people towards education

2.

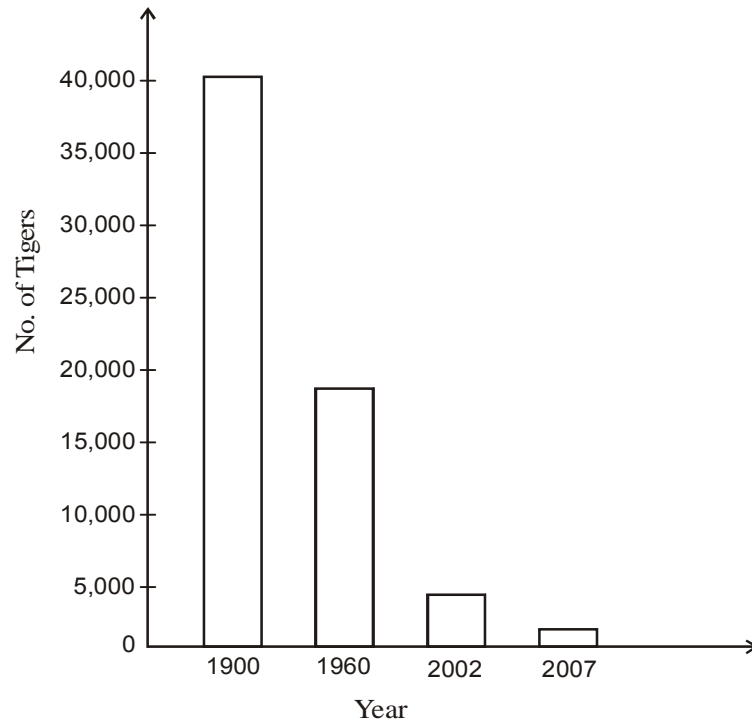

3. (a)

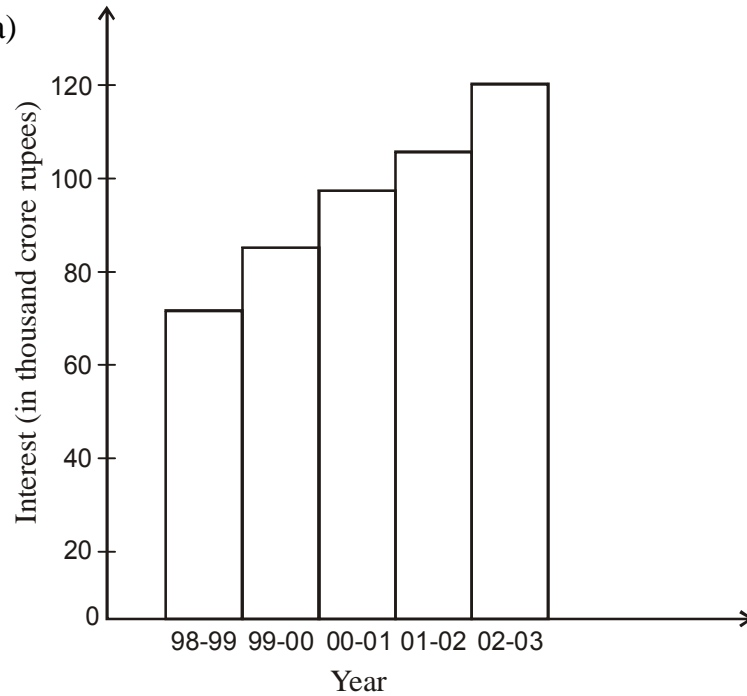

(b) We should try to be more self dependent.

4. (a) The budget was minimum in 2007-08.
 (b) The budget was maximum in 2010-11.
 (c) (i) Save the girl child.
 (ii) Improving school enrollment.
 (iii) Reducing insecurity among the parents having only daughter.

5. (a)

Class Interval	No. of plants
0-5	1
5-10	4
10-15	7
15-20	7
20-25	6

- (b) Conservation of earth by tree plantation.

6. (a) By arranging the data in ascending order, we get
 50, 75, 75, 85, 100, 100, 120, 125, 150

$$\text{Mean} = \frac{980}{10} = 98$$

$$\text{Mode} = 100$$

$$\text{Median} = \left(\frac{5^{\text{th}} + 6^{\text{th}}}{2} \right) \text{term} = \frac{100 + 100}{2} = \frac{200}{2} = 100$$

- (b) Habit of giving donation for social cause

7. (a)

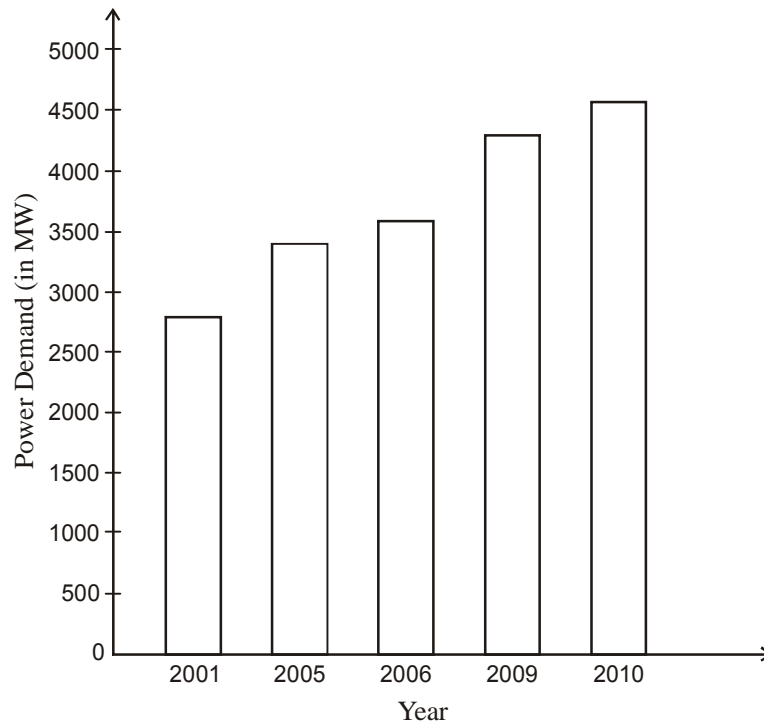

(b) Save the electricity

8. (a) In 2007, the cases of diphtheria were minimum.

(b) In 2006 and 2007, no death due to diphtheria occur.

(c) The vaccination programme should be implemented to reduce cases as well as deaths due to diphtheria.

(d) Community services

9. (a)

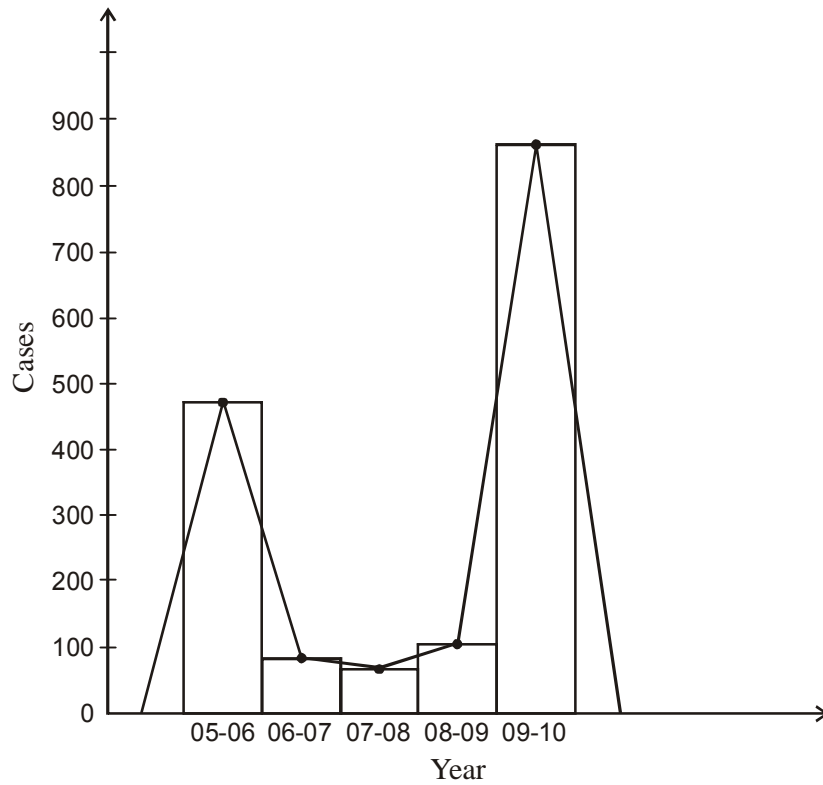

(b) Community services

10. (a) Arranging in ascending order

7, 10, 10, 10, 12, 13, 14, 15, 16, 20

$$\text{Mean} = \frac{7+10+10+10+12+13+14+15+16+20}{10} = \frac{127}{10} = 12.7$$

$$\text{Mode} = 10$$

$$\text{Median} = \frac{5^{\text{th}} + 6^{\text{th}} \text{ term}}{2} = \frac{12+13}{2} = \frac{25}{2} = 12.5$$

(b) Social service

PROBABILITY

1. 1500 families with 2 children were selected randomly, and the following data were recorded—

No. of girls in a family	2	1	0
No. of families	800	500	200

- (a) Compute the probability of a family having 2 girls.
 (b) What value is promoted by this data ?
2. On the occasion of Independence Day celebration out of 1200 students, 900 students took part in this celebration.
- (a) Evaluate the probability that the students participated in the celebration.
 (b) What values are represented through this activity ?
3. Sita says that in word MADAM, the probability of letter M is equal to that letter A. Is she right? What value represents in it ?
4. In 1000 families 750 families have 1 child and rest of families have two children. Find the probability of having (a) 1 child and (b) two children

What value represents from this ?

5. In a colony, 920 out of 1000 people visited Radha Krishan Temple on the occasion of Janamashtmi. Find the probability of people not visited the temple. What value represents in this ?
6. In a school, 100 students took part in Van Mahotsava and helped each other in planting the tree.

Name of plants	Rose	Mari gold	Chameli	Jasmine
No. of plants	32	28	16	24

Find the probability of planting

- (a) Rose (b) Jasmine

What value represents here ?

7. Mohan earns Rs. 30,000 in a month. He spends Rs. 25,000 on his needs. What is the probability of his saving ? What value is depicted from it ?
8. In a town out of 1000 persons, 998 are literate. Calculate the probability that a selected person is
(a) Literate (b) Illiterate
What value do this data represent ?
9. The blood groups of 15 students of class IX are recorded as follows—
A, B, O, O, AB, O, A, O, B, A, O, B, A, O, O, AB
Find the probability of blood group—
(a) O
(b) A
(c) What value do you draw from this activity ?
10. On Lajpat Nagar crossing, out of 100 people, 9 people jumped traffic light. Find the probability of people not jumping traffic light. What value is depicted from this ?

ANSWER

1. (a) $\frac{800}{1500} = \frac{8}{15}$
(b) Promotion to girl child
2. (a) $\frac{900}{1200} = \frac{3}{4}$
(b) Love for Nation
3. (a) $P(M) = P(A) = \frac{2}{5}$
(b) Truth value

4. (a) $\frac{750}{1000}$ or $\frac{3}{4}$
(b) $\frac{250}{1000}$ or $\frac{1}{4}$
(c) (i) Population control
(ii) Small family is a happy family
5. (a) $\frac{80}{1000}$ or $\frac{2}{25}$
(b) Spiritual value
6. (a) $\frac{32}{100}$ or $\frac{8}{25}$
(b) $\frac{24}{100}$ or $\frac{6}{25}$
(c) (i) Environmental protection
(ii) Co-operation
7. (a) $\frac{5000}{30000}$ or $\frac{1}{6}$
(b) Habit of saving
8. (a) $\frac{998}{1000}$ or $\frac{499}{500}$
(b) $\frac{2}{1000}$ or $\frac{1}{500}$
(c) Literacy rate is high in cities.

- 9 (a) $\frac{7}{15}$
- (b) $\frac{4}{15}$
- (c) (i) Habit of donation
(ii) Social work
- 10 (a) $\frac{91}{100}$
- (b) Society becomes aware to avoid accidents and save precious life.