

Chapter 14

Mensuration

Surface Area and Volume

Conversion of one solid into another solid

Some time we have to melt one solid and convert it to another shape. For example we have to convert a metallic sphere to wire in the form of cylinder. The earth taken out from a well and is spread around to make embankment of the form of cylindrical shell.

Example 1. A rectangular sheet of paper 44cm X 18cm is rolled along its length and a

cylinder is formed. Find the volume of the cylinder. [Use $\pi = \frac{22}{7}$]

Solution:-

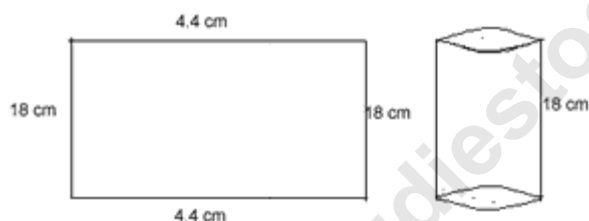

Let height, h of the cylinder be 18cm

Circumference of the base = $2\pi r$

Now,

$$2\pi r = 44$$

$$2 \times \frac{22}{7} \times r = 44$$

$$\therefore r = 44 \times \frac{7}{22} \times \frac{1}{2} = 7 \text{ cm}$$

$$\therefore \text{Volume of the cylinder} = \pi r^2 h$$

$$\begin{aligned} &= \frac{22}{7} \times 7^2 \times 18 \\ &= 2772 \text{ cm}^3 \end{aligned}$$

Example 2. How many metres of cloth 1.1m wide will be required to make a conical tent

whose vertical height is 12cm and base radius is 16m? Find also the cost of the cloth used at the rate of Rs. 14 per metre.

Solution:- Radius, r of base of conical tent = 16m.

Height, h of tent = 12m

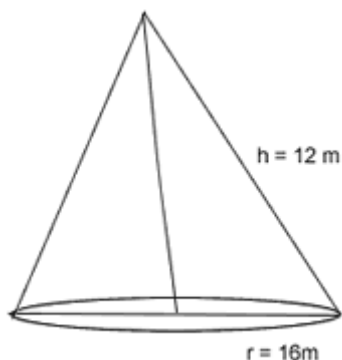

$$\begin{aligned} \text{Slant height } l &= l = \sqrt{h^2 + r^2} \\ &= \sqrt{12^2 + 16^2} \\ &= 20m \end{aligned}$$

Curved surface area of the tent

$$\begin{aligned} &= \pi r l \\ &= \frac{22}{7} \times 16 \times 20 \\ &= \frac{7040}{7} m^2 \end{aligned}$$

$$\text{Area of cloth} = \frac{7040}{7} m^2$$

$$\text{Width of the cloth} = 1.1m$$

Length of the cloth = Area/width

$$\begin{aligned} &= \frac{7040}{7} \div 1.1 \\ &= \frac{7040}{7} \times \frac{10}{11} = \frac{6400}{7} m = 914.29m \end{aligned}$$

$$\text{Cost of } \frac{6400}{7}m \text{ cloth} = \text{Rs. } 14 \times \frac{6400}{7} = \text{Rs. } 12800.$$

Example 3. If the radii of the circular ends of a bucket, 45cm high, are 28cm and 7cm, find the capacity of the bucket.

Solution:- Height, h = 45cm

Radius, $R = 28\text{cm}$

Radius, $r = 7\text{ cm}$

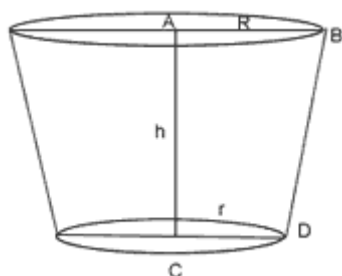

capacity of the bucket

$$\begin{aligned}
 &= \frac{1}{3} \pi h (R^2 + r^2 + Rr) \\
 &= \frac{1}{3} \times \frac{22}{7} \times 45 \times [28^2 + 7^2 + 28 \times 7] \\
 &= \frac{1}{3} \times \frac{22}{7} \times 45 \times 7^2 \times [4^2 + 1 + 4] \\
 &= \frac{1}{3} \times 22 \times 45 \times 7 \times 21 \\
 &= 48510 \text{ cm}^3
 \end{aligned}$$

Example 4. A solid sphere of radius 3cm is melted and then cast into small spherical balls each of diameter 0.6cm. Find the number of small balls thus obtained.

Solution:- Let number of small balls be x

\therefore Volume of x small balls = Volume of sphere

$$\begin{aligned}
 \frac{4}{3} \pi (0.3)^3 x &= \frac{4}{3} \pi (3)^3 \\
 x &= \frac{\frac{4}{3} \times \pi \times 3 \times 3 \times 3}{\frac{4}{3} \times \pi \times \frac{3}{10} \times \frac{3}{10} \times \frac{3}{10}}
 \end{aligned}$$

$$x = 1000$$

Example 5. A hemispherical bowl of contains some liquid. This liquid is to be filled into cylindrical shaped bottles each of diameter 5cm and height 6cm. Find the number of bottle necessary to empty the bowl.

Solution:- Inner radius R of the bowl = $30/2 = 15\text{cm}$

Inner radius r of the bottles = $5/2$ cm

Height, h of bottles = 6cm

Let no. of bottles required be x

\therefore Vol of x bottle = vol. of hemisphere

$$\begin{aligned} \pi r^2 h \times x &= \frac{1}{2} \times \frac{4}{3} \times \pi R^3 \\ x &= \frac{\frac{2}{3} \times \pi \times 15 \times 15 \times 15}{\pi \times \frac{5}{2} \times \frac{5}{2} \times 6} \\ &= \frac{2 \times 15 \times 15 \times 15 \times 2 \times 2}{3 \times 5 \times 5 \times 6} \\ &= 60 \end{aligned}$$

\therefore No. of bottles = 60

Exercise - 27

- The total surface area of a closed right circular cylinder is $65/2\text{cm}^2$ and the circumference of its base is 88cm. Find the volume of the cylinder.
- The volume of a vessel in the form of a right circular cylinder is $448\pi\text{cm}^3$ and its height is 7cm. Find the radius of its base.
- The height of a cylinder is 15cm and its curved surface area is 660 sq.cm. Find its radius.
- A cylindrical tank has a capacity of 6160 cu.cm. Find its depth if the diameter of its base is 28m. Also, Find the area of the inside curved surface of the tank.
- The volume of a right circular cylinder is 1100 cu.cm and the radius of its base is 5cm. Find its curved surface area.
- If the radius of the base of a right circular cylinder is halved, keeping the height same, find the ratio of the volume of the reduced cylinder to that of the original cylinder.
- 50 circular plates, each of radius 7cm and thickness 0.5cm are placed one above the other to form a solid right circular cylinder. Find the total surface area and volume of the cylinder so formed.
- A well of diameter 3m is dug 14m deep. The earth taken out of it has been spread evenly all around it to a width of 4m to form an embankment. Find the height of the embankment formed.
- The base radii of two right circular cones of the same height are in the ratio 3 : 5. Find the ratio of their volume.
- If h , c and v respectively are the height, the curved surface and volume of a cone, prove that $3\pi v h^3 - c^2 h^2 + 9v^2 = 0$
- The circumference of the base of a 16 m high solid cone is 3m. Find the volume of the cone.

12. A right circular cone of height 4 cm has a curved surface area 47.1 cm^2 . Find its volume (*Take $\pi = 3.14$*).
13. How many metres of cloth 5m wide will be required to make a conical tent, the radius of whose base is 7m and whose height is 24m?
14. A right triangle with sides 3cm and 4cm is revolved around its hypotenuse. Find the volume of the double cone thus generated.
15. The radius of a sphere is 7cm. If the radius be increased by 50%, find by how much percent its volume is increased.
16. The largest sphere is carved out of a cube of side 7cm. Find the volume of the sphere.
17. If the surface area of sphere is 616cm^2 , find its volume.
18. The volume of two spheres are in the ratio 64 : 27. Find their radii if the sum of their radii is 21cm.
19. The circumference of the edge of a hemispherical bowl is 132cm. Find the capacity of the bowl.
20. The internal and external diameters of a hollow hemispherical vessel are 24cm and 25cm respectively. If the cost of painting 1cm^2 of the surface area is Rs. 5.25, find the total cost of painting the vessel all over (*Take $\pi = 3.14$*).
21. A bucket of height 8cm and made up of copper sheet is in the form of frustum of a right circular cone with radii of its lower and upper ends as 3cm and 9cm respectively. Calculate:
 - (i) The height of the cone of which the bucket is a part
 - (ii) The volume of water which can be filled in the bucket.
 - (iii) The area of copper sheet required to make the bucket.
22. A bucket is in the form of a frustum of a cone and holds 28.490 litres of water. The radii of the top and bottom are 28cm and 21cm respectively. Find the height of the bucket
23. The radii of the faces of a frustum of a cone are 3cm and 4cm and its height is 5 cm. Find its volume.
24. A cone of radius 10cm is divided into two parts by drawing a plane through the mid-point of its axis, parallel to its base compare the volume of two parts.
25. A hollow cone is cut by a plane parallel to the base and the upper portion is removed. If the curved surface of the remainder is $\frac{8}{9}$ of the curved surface of the whole cone, find the ratio of the line segments into which the attitude of the cone is divided by the plane.
26. Marble of diameter 1.4cm are dropped into a cylindrical beaker of a diameter 7cm, containing some water. Find the number of marbles that should be dropped into the beaker so that the water level rises by 5.6cm.
27. Sphere of diameter 5cm is dropped into a cylindrical vessel partly filled with water. The diameter of the base of the vessel is 10cm. If the sphere is completely submerged, by how much will the level of water rise?
28. A cone is 8.4cm high and the radius of its base is 2.1cm. It is melted and recast into a sphere. Find the radius of the sphere.
29. A cone and a hemisphere have equal bases and equal volumes. Find the ratio of their heights.
30. A conical vessel whose internal radius is 5cm and height 24cm is full of water. The water is emptied into a cylindrical vessel with internal radius 10cm. Find the height

- to which the water rises in the cylindrical vessel.
31. A spherical cannon ball, 28cm in diameter is melted and cast into a right circular conical mould, the base of which is 35cm in diameter. Find the height of the cone.
 32. The radii of the internal and external surface of a metallic shell are 3cm and 5cm respectively. It is melted and recast into a solid right circular cylinder of height $10\frac{2}{3}$ cm. Find the diameter of the base of the cylinder.
 33. A solid metallic sphere of diameter 21cm is melted and recasted into a number of smaller cones, each of diameter 7cm and height 3cm. Find the number of cones so formed.
 34. A solid metallic cylinder of radius 14cm and height 21cm is melted and recast into 72 equal small spheres. Find the radius of one such sphere.
 35. The diameter of a sphere is 42cm. It is melted and drawn into a cylindrical wire of 28cm diameter. Find the length of the wire.
 36. The largest sphere is carved out of a cube of side 7cm. Find the volume of the sphere.
 37. A solid sphere of radius 6cm is melted into a hollow cylinder of uniform thickness. If the external radius of the base of the cylinder is 5cm and its height is 32cm. find the uniform thickness of the cylinder.
 38. A spherical shell of lead, whose external diameter is 18cm, is melted and recast into a right circular cylinder, whose height is 8cm and diameter 12cm. Determine the internal diameter of the shell.
 39. The diameters of the internal and external surfaces of a hollow spherical shell are 6cm and 10cm respectively. If it is melted and recast into a solid cylinder of diameter 14cm, find the height of the cylinder.
 40. A hemispherical bowl of internal radius 9cm. is full of water. This water is to be filled in cylindrical bottles of diameter 3cm and height 4cm. Find the number of bottles needed to fill the whole water of the bowl.
 41. The internal and external radii of a hollow sphere are 3cm and 5cm respectively. The sphere is melted to form a solid cylinder of height $2\frac{2}{3}$ cm. Find the diameter and curved surface area of the culinder.

Answers

- | | | |
|---------------------------|--|---------------------------|
| 1. 36960cm | 2. 8cm | 3. 7cm |
| 4. 10m, 880m ² | 5. 440sqm | 6. 1 : 4 |
| 7. 3850cm | 8. 1.125m | 9. 9 : 25 |
| 10. 462cu m | 12. 37.68cm | 13. 110m |
| 14. 3017cm ³ | 15. 237.5% | 16. 179.67cm ³ |
| 17. 1437.33cm | 18. 9cm, 12cm | 19. 19404cm ³ |
| 20. Rs. 10101.18 | 21. 12cm, $312\pi \text{ cm}^3$,
$129\pi \text{ cm}^3$ | 22. 15cm |

23. 193.8cm^3

24. $1 : 7$

25. $1 : 2$

26. 150

27. $5/6\text{cm}$

28. 2.1cm

29. $2 : 1$

30. 2cm

31. 35.84cm

32. 7cm

33. 126

34. 3.5cm

35. 63 cm

36. 179.67 cm

37. 1 cm

38. $6(19)\frac{1}{3}\text{cm}$

39. $8/3\text{ cm}$

40. 54

41. 14 cm, 117.3cm^3

Combination of Solids

In our day-to-day life we come across different solids which are combination of two or more solids. For example, top is a combination of a hemisphere and cone, circus tent is a combination of cone and cylinder. In this section we shall deal with such types of solid and find their surface area and volume.

Example 6. A solid toy is in the form of a hemisphere surmounted by a right circular cone. If height of the cone is 4cm and diameter of the base is 6cm, Calculate:

1. The volume of the toy
2. The surface area of the toy. (Use $\pi = 3.14$)

Solution:- Radius, r of cone = $6/2 = 3\text{cm}$

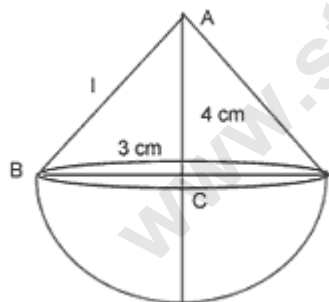

Height, h of cone = 4cm

Radius, r of hemisphere = 3cm

$$\text{Slant height } l = \sqrt{h^2 + r^2}$$

$$= \sqrt{4^2 + 3^2}$$

$$= \sqrt{16 + 9}$$

$$= \sqrt{25}$$

$$= 5\text{cm}$$

(i) Volume of the toy = volume of cone + volume of hemisphere

$$\begin{aligned}
 &= \frac{1}{3}\pi r^2 h + \frac{2}{3}\pi r^3 \\
 &= \frac{1}{3}\pi r^2 (h + 2r) \\
 &= \frac{1}{3} \times 3.14 \times 3^2 \times (4 + 2 \times 3) \\
 &= 3.14 \times 3 \times 10 = 94.20 \text{cm}^3
 \end{aligned}$$

(ii) Surface area of the toy = Curve surface area of cone + curved surface area of hemisphere

$$\begin{aligned}
 &= \pi r l + 2\pi r^2 \\
 &\pi r (l + 2r) \\
 &= 3.14 \times 3 \times (5 + 2 \times 3) \\
 &= 103.62 \text{cm}^2
 \end{aligned}$$

Example 7. A circus tent is cylindrical to a height of 3m and conical above it. If its base radius is 52.5m and slant height of the conical portion is 53m, find the area of the canvas needed to make the tent.

Solution:- Radius of the cylinder

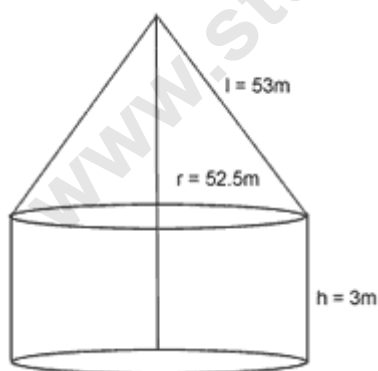

= Radius of the cone = 52.5m

Height of the cylinder = 3m

Slant height of the cone = 53m

Area of the canvas = curved surface area of cone + curved surface area of cylinder

$$\begin{aligned}
 &= \pi r l + 2\pi r h \\
 &= \pi r(l + 2h) \\
 &= 22/7 \times 52.5(53 + 2 \times 3) \\
 &= 97.35m^2
 \end{aligned}$$

Example 8. A boiler is in the form of cylinder 2m long with hemispherical ends each of 2m diameter. Find the volume of the boiler.

Solution:- Length of cylindrical portion = h = 2m

Radius of cylinder = Radius of hemisphere

$$= r = 1m$$



Volume of boiler = Volume of cylinder + volume of two hemispheres

$$\begin{aligned}
 &= \pi r^2 h + 2 \times \frac{2}{3} \pi r^3 \\
 &= \pi r^2 \left(h + \frac{4}{3} r \right) \\
 &= \frac{22}{7} \times 1 \times 1 \times \left(2 + \frac{4}{3} \times 1 \right) \\
 &= \frac{22}{7} \times \frac{10}{3} \\
 &= 10.4m^3
 \end{aligned}$$

Exercise - 28

1. A solid is in the form of a right circular cone mounted on a hemisphere. The radius of the hemisphere is 2.1cm and the height of the cone is 4cm. The solid is placed in a cylindrical tub, full of water, in such a way that the whole solid is submerged in water. If the radius of the cylinder is 5cm and its height is 9.8cm, find the volume of the water left in the cylindrical tub.
2. A solid wooden toy is in the shape of a right circular cone mounted on a hemisphere. If the radius of the hemisphere is 4.2cm and the total height of the toy

is 10.2cm, find the volume of the wooden toy.

3. A toy is in the form of a cone mounted on a hemisphere of radius 7cm. The total height of the toy is 14.5cm. Find the volume and the total surface area of the toy..
4. A toy is in the form of a cone mounted on a hemisphere of radius 3.5cm. The total height of the toy is 15.5cm. Find the total surface area and the volume of the toy.
5. A building is in the form of a hemispherical vaulted dome and contains $41\frac{19}{21} m^3$ of air. If the internal diameter of the building is equal to its total height above the floor, find the height of the building.
6. A circus tent is in the shape of a cylinder surmounted by a cone. The diameter of the cylindrical part is 24m and its height is 11m. If the vertex of the tent is 16m above the ground, find the area of canvas required to make the tent.
7. An iron pillar has some part in the form of a right circular cylinder and remaining in the form of a right circular cone. The radius of the base of each of cone and cylinder is 8cm. The cylindrical part is 240cm high and the conical part is 36cm high. Find the weight of the pillar if one cu.cm of iron weight 7.8 grams.
8. A circus tent is made of canvas and is in the form of a right circular cylinder and a right circular cone above it. The diameter and height of the cylindrical part of the tent are 176m and 5m respectively. The total height of the tent is 21m. Find the total cost of the tent if the canvas used costs Rs. 12 per square meter.
9. A circus tent has cylindrical shape surmounted by a conical roof. The radius of the cylindrical base is 20m. The height of cylindrical and conical portions are 4.2m and 2.1m respectively. Find the volume of tent.
10. A petrol tank is a cylinder of base diameter 21cm and 18cm length fitted with conical ends each of axis length 9cm. determine the capacity of the tank.

Answers

- | | | |
|-------------------------------|---------------|-----------------------------|
| 1. 732.12cu cm | 2. 266.11cm | 3. $231cm^3$, $203.94cm^2$ |
| 4. $214.5cm^2$, $243.8 cm^3$ | 5. 4m | 6. $1320m^2$ |
| 7. 395.37kg | 8. Rs. 178200 | 9. 6160m |
| 10. $8316cm^3$ | | |
-